



Self-Generation Incentive Program

Provides financial incentives for installing clean, efficient, on-site distributed generation



A  Sempra Energy utility™



SOUTHERN CALIFORNIA
EDISON
An EDISON INTERNATIONAL® Company

San Diego
**REGIONAL
ENERGY
OFFICE**



A  Sempra Energy utility™



*Pacific Gas and
Electric Company*

What's New

July 1, 2006 Revisions

2006 Self-Generation Incentive Program

On July 1, 2006, revisions were made to the Self-Generation Incentive Program (SGIP) and Handbook. This page summarizes the revisions included in this version.

1. PV Incentive Reduction Trigger (Section 3.2)

As part of Decision 06-01-024 "Interim Order Adopting Policies and Funding for the California Solar Initiative", issued January 12, 2006, the CPUC adopted an automatic schedule to reduce photovoltaic incentives if program participation exceeds a pre-determined capacity level. The Table below summarizes the trigger levels for 2006.

Incremental MW	Incentive Rate (\$/watt)
	2.80
50	2.50
70	2.25

2. Renewable Fueled Generators

➤ *Renewable Fuel system rating (Section 2.5.4)*

For Level 2 technologies (except wind turbines), the generating system capacity is the operating capacity based on the average annual available Renewable Fuel flow rate, including allowable Non-Renewable Fuel, and is the capacity that the incentive amount is based.

➤ *Definition of Renewable Fuel (Section 2.6.1.)*

Increasing an existing generator's Non-Renewable Fuel consumption to increase the available Renewable Fuel resource for a new SGIP proposed generator is not allowed.

➤ *Level 2 (Renewable Fuel) Incentive Calculation (Section 3.4.1)*

For fuel cells, microturbines, internal combustion engines and gas turbines on Renewable Fuels an incentive will be paid based on the operating capacity resulting from the average annual available Renewable Fuel flow rate, including allowable Non-Renewable Fuel. The nameplate rated capacity of the generator must not exceed the peak electric load at the site.

➤ *Substantiation of Renewable Fuel resource (Section 4.6.3)*

For Projects where Host Customer provided Renewable Fuel resource estimates, Incentive Claim materializes must include documentation demonstrating that the Renewable Fuel resource has materialized.

3. Application Fee Payment (Section 4.3)

At their discretion, Program Administrators may allow the Application Fee to be sent in with the Reservation Request Form and Required Attachments. Refer to the Reservation Request Form Checklist on the Program Administrators web site to determine if this is allowed.

4. Public Entities

➤ *Reservation for Public Entities (Section 4.4)*

Once the application has successfully met Proof of Project Advancement requirements the Program Administrator will issue a Reservation Confirmation and Incentive Claim Form with a Reservation Expiration Date of 12-months from the date of the initial Conditional Reservation Notice Letter for non-public entities and 18-months from the date of the initial Conditional Reservation Notice Letter for Public Entities.

➤ *Proof of Project Advancement due date for Public Entities (Section 4.5)*

Public Entities, within 60 calendar days of the date the Conditional Reservation Letter, must submit a copy of the issued request for proposal (RFP or equivalent) for purchase or installation of the generating system and within 240 calendar days of the date the Conditional Reservation Letter satisfy all Proof of Project Advancement criteria, including returning a signed SGIP Contract.

Table of Contents

1	INTRODUCTION	1-1
1.1	Program Summary.....	1-1
1.2	Program Background.....	1-1
1.3	Program Modification.....	1-3
2	PROGRAM ELIGIBILITY CRITERIA AND REQUIREMENTS	2-1
2.1	Effective Dates.....	2-1
2.2	Host Customer Eligibility	2-1
2.3	System Owner Eligibility	2-2
2.4	Applicant Eligibility	2-2
2.5	Generator System Equipment Eligibility.....	2-3
2.5.1	Equipment Must Serve On-Site Electrical Load.....	2-3
2.5.2	Hybrid Systems	2-3
2.5.3	Equipment and Installation Certifications.....	2-4
2.5.4	Rating Criteria for System Output.....	2-4
2.5.5	Minimum Size.....	2-5
2.5.6	Maximum Size.....	2-5
	2.5.6.1 System Sizing for Sites with Energy (kWh) Data Only (No Peak Demand “kW” Metering).....	2-6
	2.5.6.2 System Sizing Based on Future Load Growth	2-6
2.5.7	Not Eligible under the SGIP.....	2-6
2.5.8	Waste Heat Utilization Requirement.....	2-7
2.5.9	Fossil Fuel Combustion Emission & Minimum System Efficiency Standards	2-9
	2.5.9.1 Fossil Fuel Combustion Emission Eligibility Requirements.....	2-9
	2.5.9.2 Fossil Fuel Combustion Emission Credits.....	2-10
	2.5.9.3 Exemptions for Waste Gas Systems.....	2-14
2.5.10	Eligibility of Replacement Generation.....	2-14
2.5.11	Reliability Criteria.....	2-14
2.5.12	Warranty Requirements.....	2-15
	2.5.12.1 Photovoltaic, Wind Turbine & Fuel Cell System Warranty Requirements.....	2-15
	2.5.12.2 Microturbine, Internal Combustion Engine & Gas Turbine System Warranty and/or Maintenance Requirements.....	2-15
2.5.13	Interconnection to the Utility Distribution System.....	2-16
2.5.14	Permanent Installation.....	2-16
2.5.15	New Equipment, Not Pilot or Demonstration Systems.....	2-17
	2.5.15.1 Alternative Criteria for Generating System Eligibility – Third Party Certification	2-17
	2.5.15.2 CEC’s Emerging Renewables Program – Renewable Equipment Eligibility	2-17
2.6	Eligible Fuels	2-17
2.6.1	Renewable Fuels.....	2-17
2.6.2	Non-Renewable Fuels	2-18

2.6.3	Waste Gas Fuels	2-18
2.7	Incentives from Other Sources	2-19
3	INCENTIVES	3-1
3.1	Incentive Levels	3-1
3.2	Incentive Reduction Trigger for Photovoltaic Technologies	3-2
3.3	Incentive Limitations	3-3
3.3.1	Total Eligible Project Costs.....	3-3
3.3.2	Other Incentives or Rebates	3-3
3.3.3	Site and Host Customer Limitations	3-5
3.4	Calculating the Incentive.....	3-5
3.4.1	Level 2 (Renewable Fuel) Incentive Calculation.....	3-6
3.4.2	Incentive for Systems with Output Capacity above 1 MW	3-6
3.5	Hybrid System Incentives	3-7
4	APPLICATION PROCESS.....	4-1
4.1	Overview of the Application Process	4-1
4.2	Assignment of SGIP Application Rights & Responsibilities.....	4-2
4.3	Application Fee	4-3
4.4	Reserving an Incentive	4-5
4.4.1	Reservation Request Form.....	4-5
4.4.2	Required Attachments	4-5
4.4.3	Submitting the Reservation Request Form.....	4-9
4.4.4	Application Screening.....	4-9
4.4.5	Incomplete Reservation Requests.....	4-9
4.4.6	Approved Reservation Request Form	4-9
4.4.7	Waiting List Procedures.....	4-9
4.4.8	Conditional Reservation Notice Letter	4-10
4.4.9	Reservation Period.....	4-10
4.5	Proof of Project Advancement	4-11
4.5.1	Required Attachments	4-11
4.5.2	Changes to the Proposed System	4-15
	4.5.2.1 Substantive Changes to the Proposed Project	4-15
	4.5.2.2 System Changes Affecting Incentive Amount.....	4-15
4.5.3	Submitting Proof of Project Advancement	4-15
4.5.4	Incomplete Proof of Project Advancement	4-15
4.5.5	Proof of Project Advancement Extensions	4-16
4.5.6	Submitting the Executed Contract or Agreement for System Installation or Lease for Public Entities.....	4-16
4.5.7	Approval of Proof of Project Advancement.....	4-16
4.6	Reservation Confirmation and Incentive Claim Form.....	4-17
4.6.1	Extending the Reservation Expiration Date	4-17
4.6.2	Requesting an Incentive Payment.....	4-17

4.6.3	Required Attachments	4-17
4.6.4	Changes to the Proposed System	4-20
	4.6.4.1 Substantive Changes to the Proposed Project	4-20
	4.6.4.2 System Changes Affecting Incentive Amount	4-21
4.6.5	Submitting Your Incentive Claim Form	4-21
4.6.6	Reservation Confirmation and Incentive Claim Submittals	4-22
4.6.7	Field Verification Visit	4-22
	4.6.7.1 Failed Field Verification	4-22
4.6.8	Incentive Check Payment and Terms	4-22
5	OTHER INSTALLATION REQUIREMENTS & CONTINUING SITE ACCESS REQUIREMENTS	5-1
5.1	Connection to the Utility Distribution System	5-1
	5.1.1 How to Apply For Interconnection of Self Generation Systems	5-1
5.2	Measurement and Evaluation (M&E) Activities	5-2
	5.2.1 Field M&E Visits	5-3
	5.2.2 Electrical Metering Requirements	5-3
	5.2.3 Other Energy Metering Requirements	5-3
	5.2.4 M&E System Monitoring Data Transfer Requirements	5-4
	5.2.5 Disposition of SGIP Metering Equipment	5-4
6	DEFINITIONS AND GLOSSARY	6-1
7	PROGRAM ADMINISTRATOR CONTACT INFORMATION	7-1
	APPENDIX A ELIGIBLE PROJECT COST ITEMS FOR LEVEL 1 PV SYSTEMS	7-2
	APPENDIX B DESCRIPTION OF TOTAL ELIGIBLE PROJECT COSTS	7-3
	APPENDIX C CONVERSION OF EMISSIONS PPM TO LB/MWH	7-5
	INDEX	7-7

1 INTRODUCTION

This handbook establishes the policies and procedures of the Self-Generation Incentive Program (SGIP) for potential program participants and other interested parties. It is the joint work product of Pacific Gas and Electric (PG&E), Southern California Edison (SCE), the Southern California Gas Company (SoCalGas), San Diego Regional Energy Office (SDREO), San Diego Gas & Electric (SDG&E), California Energy Commission (CEC) and the Energy Division of the California Public Utilities Commission (CPUC). The SGIP has been approved by the CPUC and is subject to change in whole or in part at any time without prior notice. Any changes made to the SGIP will be published in revisions to this Handbook and/or posted at each Program Administrator's website under "Interim Changes".¹

1.1 Program Summary

The SGIP provides financial incentives for the installation of new, qualifying self-generation equipment installed to meet all or a portion of the electric energy needs of a facility. The SGIP complements the existing California Energy Commission's (CEC's) Emerging Renewables Program (ERP)² by providing incentive funding to larger renewable and non-renewable self-generation units up to the first 1.0 MW in capacity.³

PG&E, SCE, SoCalGas, and SDREO are the Program Administrators for the SGIP throughout their respective service territories.⁴

The SGIP Working Group consists of the Program Administrators and representatives from SDG&E, the California Energy Commission staff associated with the ERP, and the Energy Division of the CPUC. The Working Group is charged with the tasks of program implementation, addressing programmatic issues and maintaining statewide program uniformity.

1.2 Program Background

Assembly Bill 970 (AB 970) required the CPUC to initiate certain load control and distributed generation activities, including financial incentives. On March 27, 2001, the CPUC issued Decision 01-03-073, which ordered the state's investor-owned utilities (PG&E, SDG&E, SCE, and SoCalGas) to work with the CPUC Energy Division, the CEC and SDREO to develop and implement a self-generation equipment incentive program.

¹ Capitalized terms used herein are defined in Section 6 of this Handbook.

² The California Energy Commission's Emerging Renewables Program includes renewable self-generation systems less than 30 kW in size.

³ Maximum system size is 5 MW. However, only 1 MW of system capacity is eligible for incentives. Reference CPUC Decision 04-12-045 December 16, 2004.

⁴ SDREO is the Program Administer for SDG&E customers.

On October 12, 2003, AB 1685 extended the SGIP beyond 2004 through 2007. This bill required the CPUC, in consultation with the CEC, to administer, until January 1, 2008, a self-generation incentive program for distributed generation resources in the same form that existed on January 1, 2004, and that combustion-operated distributed generation Projects using fossil fuels commencing January 1, 2005, meet a NOx emission standard, and commencing January 1, 2007, meet a more stringent NOx emission standard and a minimum system efficiency standard, to be eligible for incentive rebates under the SGIP. The bill established a NOx emission credit that can be used by combined heat and power (CHP) units that meet the minimum system efficiency standard in order to meet the emission standard.

On September 22, 2004 AB 1684 made exempt certain Projects from the NOx emission standard set forth in AB 1685, starting in 2005, if the Project meets certain fuel and permitting requirements.

On December 16, 2004, CPUC Decision 04-12-045 modified the SGIP by implementing the provisions of AB 1685, eliminating the maximum percentage payment limits, and reducing the incentive payments for several technologies, including Level 1 solar Projects. This decision also directed the Program Administrators to expand opportunities for public input in three Working Group activities: 1) developing a declining rebate schedule, 2) developing an exit strategy, and 3) adapting a data release format.

CPUC Decision 04-12-045 also directed the SGIP Working Group to develop appropriate procedural and financial mechanisms to deter inappropriate reservation requests, or “phantom projects,”⁵ from applying to program. In response to both the directive set forth in Decision 04-12-045 and to public comments, the Working Group adopted the implementation of an Application Fee for all SGIP reservations received on or after July 1, 2005 and all applications on SGIP Wait Lists.

On December 15, 2005, CPUC Decision 05-12-044 expanded the state’s existing solar program by increasing its budget by \$300 million for 2006, reducing solar incentives to \$2.80/Watt for new 2006 Projects and allowing \$3.00 per watt for Projects on the waiting list as of December 15, 2005. It also directed the Program Administrators to refund application fees to Projects that elect to withdraw from the waiting list.

On January 12, 2006, CPUC Decision 06-01-047 established the California Solar Initiative (CSI) and ordered changes in the 2006 SGIP to accommodate the transition of solar program elements to the CSI in 2007. These changes to 2006 SGIP included the clarification of budgets, limiting eligible system size to 100% of historic peak demand for all technologies, and reorganization of incentive levels by fuel type.

CPUC Decision 06-01-024 to SGIP, issued January 12, 2006, established an incentive reduction trigger for photovoltaic systems. In a follow-up decision, CPUC Decision 06-05-025 states, “The program administrators shall automatically impose the incentive reduction when the triggers in D.06-01-024 are met, up to twice per calendar year, unless directed differently by further Commission order or ruling.” On

⁵ Inappropriate reservation requests or “phantom projects” are defined as Projects that apply to SGIP, receive a Conditional Reservation for funding and later are withdrawn or rejected.

May 25, 2006, the CPUC issued Decision 06-05-025, affirming the Administrative Law Judge's ruling of April 24, 2006, which reduces solar photovoltaic (PV) incentives from \$2.80/watt to \$2.50/watt when 50 MWs of statewide Conditional Reservations⁶ have been issued. If an additional 70 MW of Conditional Reservations has been issued (120 MW total) by December 31, 2006 then the incentive will be reduced to \$2.25/W. Check the SGIP Program Administrators' websites for the status of the incentive trigger.

1.3 Program Modification

Since initiating the SGIP, the CPUC has received several petitions for modification to add new technologies to the SGIP, as well as requesting other related programmatic changes. On August 21, 2003, the CPUC issued Decision 03-08-013 that instructed the SGIP Working Group to implement a more effective process by which the CPUC could consider proposed new technologies or SGIP rule changes that does not rely on procedures related to petitions for modification.

The Working Group developed a process for interested parties to use to propose new technologies or SGIP rule modifications to the Working Group and the CPUC for careful and complete consideration in an efficient manner. This process, described in the Program Modification Guidelines (PMG), prescribes the proposal requirements, evaluation process and schedule. The latest PMG is available from any of the Program Administrators' websites.

⁶ Conditional Reservation Notice Letter is issued when Reservation Applications have met all requirements and the Application Fee has been paid.

2 PROGRAM ELIGIBILITY CRITERIA AND REQUIREMENTS

The eligibility criteria for the SGIP govern which utility customers and Projects can participate. In order to qualify for incentives, all program eligibility criteria must be satisfied. The following sections detail these requirements.

2.1 Effective Dates

Each Program Administrator first began accepting applications to the SGIP in the summer of 2001. AB 1685 extended the SGIP through December 31, 2007 (or until funding is exhausted). Each Program Administrator offers incentive funding on a first-come, first-served basis for each calendar year of the SGIP, subject to annual budget limits set by the CPUC. Each Program Administrator carries forward uncommitted or unspent SGIP funds for a given calendar year and applies them towards SGIP funding in the following year. Program Administrators may also reallocate unspent funds from Levels 2 and 3 to Level 1 without prior CPUC approval.

In order to be eligible for an incentive, the Host Customer or System Owner must receive a Conditional Incentive Reservation from the Program Administrator prior to the Host Customer or System Owner receiving authorization from the serving Electric Utility to operate the Project in parallel with the grid.

2.2 Host Customer Eligibility

Any retail level electric or gas distribution customer of PG&E, SCE, SoCalGas, or SDG&E is eligible to apply as the Host Customer and receive incentives from the SGIP. The Host Customer must be the utility customer of record at the Site where the generating equipment is or will be located. Any class of customer (industrial, agricultural, commercial or residential) is eligible to be a Host Customer in the SGIP. The Host Customer's Site must be located in the service territory of, and receive retail level electric or gas service⁷ from PG&E, SCE, SDG&E or SoCalGas at the Site. Municipal utility customers served by SCE, PG&E, SDG&E or SoCalGas at the Site are also eligible.

The Host Customer is the incentive reservation holder. The Host Customer may also be the Applicant and/or System Owner. In the event the Host Customer or System Owner withdraws from the Project and cancels the Host Customer and System Owner Agreement that is part of the Reservation Request Form, the Host Customer alone will retain sole rights to the incentive reservation and corresponding incentive reservation number. To preserve such incentive reservation and corresponding reservation number, the Host Customer must submit a new Reservation Request Form to the Program Administer. The Host Customer thus has the right to designate the Applicant, energy services provider, and/or system installer.

⁷ "...retail level electric or gas service..." means that the Host Customer pays for and receives distribution services, as defined by their respective utility rate schedule.

As the utility customer of record, the Host Customer shall be party to the SGIP Contract. See Section 4.2 for further information on Host Customer rights to assign responsibilities and claims.

The following Host Customers or Host Customer Loads are **not** eligible for incentives under the SGIP:

- Customers who have entered into contracts for Distributed Generation (DG) services (e.g. DG installed as a distribution upgrade or replacement deferral) and who are receiving payment for those services. This does not include Power Purchase Agreements, which are allowed.
- Customers who have entered into agreements that entail the export and sale of electricity from the Host Customer Site. This does not include Net Energy Metering agreements, which are allowed.
- Any portion of customer load that is committed to Electric Utility interruptible, curtailable rate schedules, programs or any other state agency-sponsored interruptible, curtailable, or demand-response programs. For Electric Utility customers who are on an interruptible rate, only the portion of their electric load that is designated as firm service is eligible for the SGIP. Customers must agree to maintain the firm service level at or above capacity of the proposed generating system for the duration of the required applicable warranty period (see Section 2.5.12). Customers may submit a letter requesting an exemption to the firm service rule if they plan to terminate or reduce a portion of their interruptible load.
- Publicly-owned or investor-owned gas, electricity distribution utilities or any Electrical Corporation (ref. Public Utility Code 218) that generates or purchases electricity or natural gas for wholesale or retail sales.

2.3 System Owner Eligibility

The System Owner is the owner of the generating equipment at the time the incentive is paid. For example, in the case when a vendor sells a turnkey system to a Host Customer, the Host Customer is the System Owner. In the case of a leased system, the lessor is the System Owner. The System Owner shall be designated on the Reservation Request Form, if known at that time, and on the Incentive Claim Form. If different from the Host Customer, the System Owner shall also be a party to the SGIP Contract. The Program Administrator may require documentation substantiating equipment ownership.

2.4 Applicant Eligibility

The Applicant is the entity that completes and submits the SGIP application and serves as the main point of communication between the SGIP Program Administrator throughout the application process. Host Customers may act as the Applicant or they may designate a third party to act as the Applicant on their behalf. Applicants may be third parties (e.g. a party other than the Program Administrator or the utility

customer) such as, but not limited to, engineering firms, installation contractors, equipment distributors, Energy Service Companies (ESCO), equipment lessors, etc.

The Host Customer may elect to change the Applicant at their discretion.

2.5 Generator System Equipment Eligibility

Self-generation technologies eligible for the SGIP are grouped into three incentive levels⁸ as shown in Table 2-1 below:

Table 2-1 - Technologies Eligible for SGIP Incentives

Incentive Levels	Eligible Technologies
Level 1 Solar	<ul style="list-style-type: none"> Photovoltaics (PV)
Level 2 Renewable Non-Solar	<ul style="list-style-type: none"> Fuel cells operating on Renewable Fuel Wind turbine Microturbines, internal combustion engines and gas turbines operating on Renewable Fuel
Level 3 Non-Renewable Non-Solar	<ul style="list-style-type: none"> Fuel cells operating on non-renewable fuel and utilizing sufficient waste heat recovery Microturbines, internal combustion engines and gas turbines operating on Non-Renewable Fuel or Waste Gas Fuel, utilizing sufficient waste heat recovery, meeting the reliability and emissions criteria as applicable.

2.5.1 Equipment Must Serve On-Site Electrical Load

Only self-generation equipment installed on the Host Customer's side of the utility meter is eligible. Equipment must be sized to serve all or a portion of the electrical load at the Site.

2.5.2 Hybrid Systems

A system that contains more than one type of eligible technology at one Site and behind one utility service meter is considered a "Hybrid System" and is eligible for SGIP incentives. This can include two or more of the levels listed above in Table 2-1. For example, a photovoltaic and a microturbine Hybrid System installed at a single Site may receive incentives, provided each technology meets all SGIP eligibility requirements for that technology. A system that consists of different technologies within one

⁸ The SGIP incentive levels were reorganized by CPUC Decision 06-01-047, January 12, 2006, to better suit the implementation of the California Solar Initiative.

incentive level (for example a Renewable Fuel cell and wind turbine) must be considered a Hybrid System if installed behind the same meter at the Site. See Section 3.5 for an explanation of how to calculate incentives for Hybrid Systems.

2.5.3 Equipment and Installation Certifications

The SGIP intends to provide incentives for reliable, permanent, safe systems that are professionally installed, and comply with all applicable Federal, State and local regulations. Host Customers and System Owners are strongly encouraged to become familiar with applicable equipment certifications, design, and installation standards for the systems they are contemplating. All systems must be installed by appropriately licensed California contractors in accordance with rules and regulations adopted by the State of California Contractors' State Licensing Board. Installation contractors must have an active A, B, or C-10 license, or a C-46 license for photovoltaic systems. The system installers name, telephone number and contractor license number must be included with the "Reservation Confirmation and Incentive Claim Form".

2.5.4 Rating Criteria for System Output

The rated photovoltaic system capacity must be calculated using the PVUSA Test Conditions (PTC) rating standards⁹ including inverter DC to AC losses.¹⁰ Wind turbine rated capacity is the highest electrical output from the manufacturer's power output curve for wind speeds up to 30 mph including inverter losses. For Level 2 technologies (except wind turbines), the generating system capacity is the operating capacity based on the average annual available Renewable Fuel flow rate, including allowable fossil fuel, and is the capacity that the incentive amount is based. For Level 3 technologies, the generating system rated capacity is the net continuous power output of the packaged prime mover/generator at ISO conditions¹¹ operating on a Non-Renewable fuel.

System capacity ratings are established at the time of Conditional Reservation Notification in order to determine the SGIP reservation dollar amount. If system modifications (i.e., changes in equipment make/model) are made after the Conditional Reservation Notification, the system capacity must be re-rated using currently available published component information for the changed equipment. If the number of components has increased or decreased and there is no change in the make/model of the equipment used, system components can be rated using the same published information used at the time of the Conditional Reservation Notification. Any net increase in system capacity after Conditional

⁹ PTC watt rating is based on 1,000 Watt/m² solar irradiance, 20 degree Celsius ambient temperature, and 1 meter/second wind speed. The PTC watt rating is lower than the "Standard Test Conditions" (STC), a watt rating used by manufacturers.

¹⁰ CEC Emerging Renewables Program equipment ratings and efficiency are to be used for rating of PV and Wind Turbine systems. Other sources including manufacturer specifications can be used only if the CEC has not published the model ratings for the equipment in question.

¹¹ Industry standard conditions to measure output – temperature at 59 degrees Fahrenheit and altitude at sea level (0 feet).

Reservation Notification may or may not result in an increase in the SGIP incentive amount, depending upon funding availability at the time the change is made.

2.5.5 Minimum Size

For photovoltaic, wind turbine and Renewable Fuel cell technologies, the minimum system size per Site is 30 kW.¹² There are no minimum system size criteria for microturbine, gas turbine, and internal combustion engine technologies that operate on Renewable Fuel. Additionally, there are no minimum size criteria for fuel cell, microturbine, internal combustion engine and gas turbine technologies operate on non-renewable fuel.

2.5.6 Maximum Size

The maximum eligible system size per Site is 5 MW with the maximum incentive capped at 1 MW. In addition, system rated electrical output cannot exceed the previous 12-month annual peak (maximum) demand at the customer's Site. If the Site is host to existing generation, the combined capacity of the proposed and existing generators (excluding any back-up generators) must be no more than the Host Customer's Maximum Site Electric Load. Substantiation of system sizing is required in the initial application submittal. Generating systems running on fossil fuel that have had their system output de-rated may not be eligible for the SGIP.

The System Owner/Host Customer shall substantiate that the proposed system size does not exceed 5 MW. If any of the following items submitted (preliminary and final), or actions taken, indicate a system size greater than 5 MW, the Project will be deemed ineligible.

- Required SGIP applications, submittals, and supporting documentation
- Interconnection documentation
- Building Permits
- Air Permits
- Design documents including civil, structural, electrical and mechanical systems
- Expansion construction commencing prior to payment of the incentive.

Exceptions and alternative system sizing criteria to the previous 12-month annual peak demand limit exist in the following two cases: 1) Sites with 12-months of energy usage data, but no peak demand information, and 2) applications basing system size on future load growth due to facility expansion or other load growth circumstances. Under no case may the system size exceed a rated capacity of 5 MW.

¹² Based on the system rated capacity per Section 2.5.6.

2.5.6.1 System Sizing for Sites with Energy (kWh) Data Only (No Peak Demand “kW” Metering)

Sites with 12-months of previous energy usage data (kWh), but without peak demand (kW) information available (e.g., customers on rate schedules without a demand component) will have an equivalent peak demand calculated using the following method –

$$\text{Peak Demand (kW)} = \text{Largest Monthly Bill (kWh/month)} / (\text{Load Factor} \times \text{Days/Bill} \times 24)$$

$$\text{Residential: Load Factor} = .45^{13}$$

$$\text{Small Commercial: Load Factor} = .47^{14}$$

$$\text{Agricultural: Load Factor} = .35$$

Substantiation of system sizing is required with the initial application submittal.

2.5.6.2 System Sizing Based on Future Load Growth

Applications must include an engineering estimate with appropriate substantiation of the Host Customer Site's annual peak demand forecast if the generating system size is based on future load growth, including new construction, load growth due to facility expansion or other load growth circumstances. Suggested methods of demonstrating load growth include Application for Service with corresponding equipment schedules and single line diagram; building simulation program reports such as eQUEST, EnergyPro, DOE-2, and VisualDOE; or detailed engineering calculations. The Program Administrator will verify the load growth predicted before moving forward with the Conditional Reservation Notice. Application documentation must demonstrate that sufficient load has materialized before the incentive can be paid. Additionally, adequate Site load will be verified during the field verification visit or subsequent site inspections.

If the Site load forecast or renewable fuel forecast has not yet materialized, the Applicant will be given two options; 1) Take a one time payment based on the Site load or fuel availability (whichever is less) demonstrated at the time of inspection or, 2) Wait for the Site load or fuel to materialize within 12-months of the date of inspection. If the Site load or fuel has not materialized within the 12-month period, the project will be paid based on the Site load, or system operating capacity available at the end of the 12-month period.

2.5.7 Not Eligible under the SGIP

The following types of generating systems / equipment are not eligible for the SGIP:

- Back-Up Generators - systems intended solely for emergency or back-up generation purposes
- Any system/equipment that is capable of operating on or switching to diesel fuel, or Diesel Cycle for start-up or continuous operation

¹³ Residential Load Factor estimated from California investor owned utility domestic static load profiles.

- Generating technologies not listed in Table 2-1 (Eligible Equipment Types) in Section 2.5.

2.5.8 Waste Heat Utilization Requirement

Utilization of waste heat at the Host Customer Site is required for all Level 3 systems. Waste heat utilization must meet the requirements of Public Utilities Code 218.5, which are expressed in the following equations.¹⁵

$$\text{P.U. Code 218.5 (a)} \Rightarrow T / (T + E) \geq 5\%$$

And,

$$\text{P.U. Code 218.5 (b)} \Rightarrow (E + 0.5 \times T) / F \geq 42.5\%$$

Where:

T ≡ The **annual** useful thermal output used for industrial or commercial process (net of any heat contained in condensate return and/or makeup water), heating applications (e.g., space heating, domestic hot water heating), used in a space cooling application (i.e., thermal energy used by an absorption chiller).

E ≡ The **annual** electric energy made available for use, produced by the generator, exclusive of any such energy used in the power production process.

F ≡ The generating system's **annual** Lower Heating Value (LHV) non-renewable fuel consumption.

All applications proposing Level 3 technologies must provide documentation demonstrating an ability to meet both of the minimum waste heat utilization standards stated above, including an engineering calculation of the P.U. Code 218.5 efficiencies with documented assumptions regarding the Site's thermal load.

Specifically, following documentation must be provided.

- **Generator & Thermal System Description**

The application must include the performance and capacity specifications for the proposed Combined Heat and Power (CHP) system and all thermal system equipment that the CHP system interacts with or serves. This includes but is not limited to the generator system, heat recovery system, heat exchangers, absorption chillers, boilers, furnaces, etc. In addition, a thermal

¹⁴ Small Commercial and agricultural Load Factors From "2002-2012 Electricity Outlook Report, CALIFORNIA, ENERGY COMMISSION, February 2002 P700-01-004F" Table III-2-1.

¹⁵ PUC 218.5 - "Cogeneration" means the sequential use of energy for the production of electrical and useful thermal energy. The sequence can be thermal use followed by power production or the reverse, subject to the following standards: (a) At least 5 percent of the facility's total annual energy output shall be in the form of useful thermal energy; (b) Where useful thermal energy follows power production, the useful annual power output plus one-half the useful annual thermal energy output equals not less than 42.5 percent of any natural gas and oil energy input.

process diagram must be provided as part of the documentation package that shows the configuration of the generator(s), heat recovery system, pumps, heat exchangers, thermal load equipment, and the working fluid flow and temperatures in/out of each piece of major equipment at design conditions.

- **Forecast of Generator Electric Output**

The application must include a forecast of the monthly generator electric output (kWH/month) for a twelve-month period. The generator electric output forecast must be based on the operating schedule of the generator, historical or Site electric load forecast and maximum/minimum load ratings of the generating system; exclusive of any electric energy used in ancillary loads necessary for the power production process (i.e., intercooler, external fuel gas booster, etc.).

- **Forecast of Generator Thermal Output**

The application must include a forecast of the monthly generator thermal output (Btu/month) for a twelve-month period. The generator thermal output forecast must be based on the electric output forecast of the generating system and the waste heat recovery rate specifications of the system.

- **Forecast of Generator Fuel Consumption**

The application must include a forecast of the generating systems monthly fuel consumption (Btu/month) for a twelve-month period. The generator's fuel consumption forecast must be based on the generating system electric output forecast and the systems fuel consumption specifications.

- **Forecast of Thermal Load Magnitude**

The application must include a monthly thermal load forecast (Btu/month) for a twelve-month period for the thermal load served by the CHP system. The forecast must be based on engineering calculations, thermal system modeling, historical fuel billing, measured data or a combination of these methods. The thermal load forecast must be independent of the generator operation forecast. If historical natural gas or other fossil fuel consumption records (e.g., billing records) are used, the combustion efficiency of the natural gas or fossil fuel fired equipment that is being displaced must be included. Historical fuel consumption must be discounted to account for equipment thermal load that will not be displaced by the prime mover's thermal energy.

- **Forecast of Useful Thermal Output**

The useful thermal output of the CHP system will be the lesser of the thermal load forecast, or the prime mover's thermal output coincident with the thermal load. The useful thermal output is the value used in calculating the P.U. Code 218.5 requirements.

All assumptions, backup documentation, hand calculations, models (with inputs and outputs) and custom spreadsheets used to develop the forecasts must be included in the documentation. Forecasts based solely on "professional experience" or subjective observation will be rejected. Applications must include a

completed Waste Heat/AB1685 spreadsheet, available from the Program Administrators' websites, to calculate the waste heat utilization efficiency.

2.5.9 Fossil Fuel Combustion Emission & Minimum System Efficiency Standards

In addition to the waste heat utilization requirement, Level 3 microturbine, internal combustion engine and gas turbine Projects that submit Reservation Request Forms during Program Years 2005 and 2006 must not exceed a NO_x emissions standard of 0.14 lbs/MW-hr. Level 3 microturbine, internal combustion engine and gas turbine Projects that submit Reservation Request Forms during Program Year 2007 must not exceed a NO_x emissions standard of 0.07 lbs/MW-hr. If these Projects fail to meet the emission standard, but meet the 60% minimum system efficiency standard, then an emission credit may be determined to adjust the final emissions determination of eligibility. Note that all Level 3 microturbine, internal combustion engine and gas turbine Projects that submit Reservation Request Forms during Program Year 2007 must meet the 60% minimum system efficiency requirement. The following chart shows schematically the eligibility requirements, which are further detailed below.

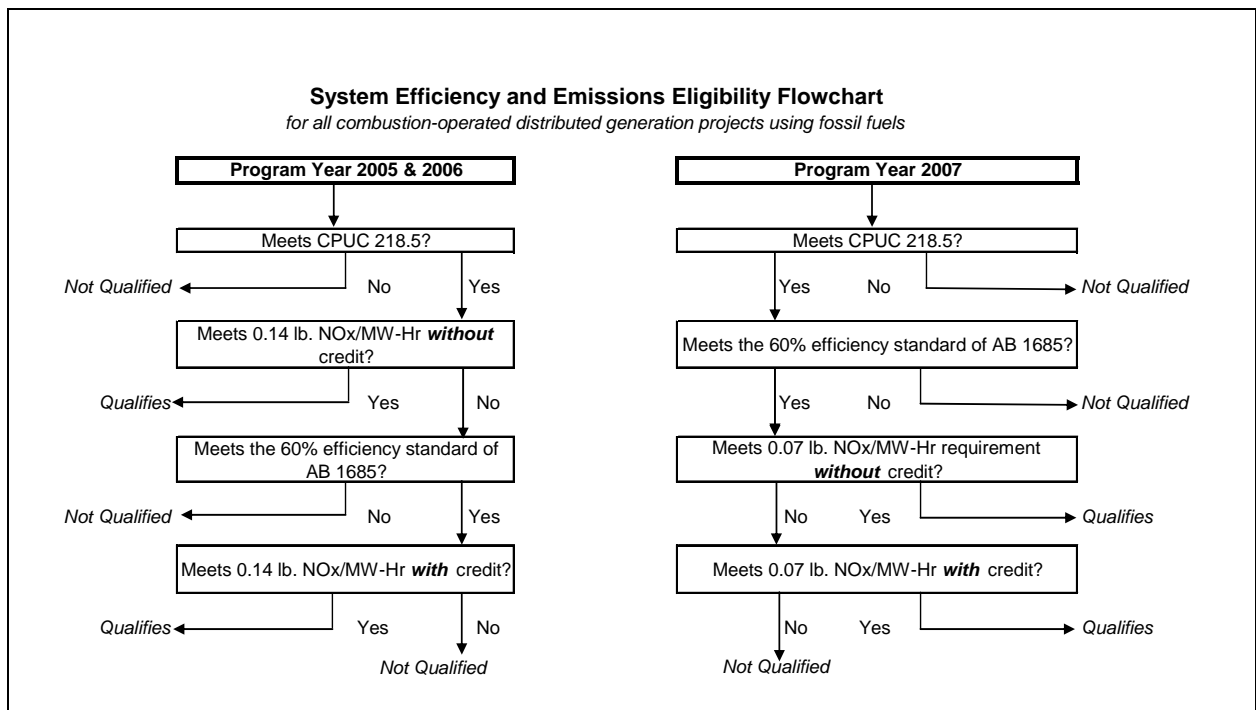

Figure 2-1 AB 1685 Eligibility Requirement Flowchart

2.5.9.1 Fossil Fuel Combustion Emission Eligibility Requirements

The application must include documentation demonstrating that the proposed generator will not exceed the applicable NO_x emission standard (Program Years 2005 & 2006 = .14 lb/MWh; Program Year 2007 =

.07 lb/MWh). At the Reservation Request stage, the application must include one of the following documents to determine the NOx emissions (lb/MWh) of the proposed system.

- Manufacturer emission specifications based on factory testing using California Air Resources Board (CARB), EPA or local air district test methods¹⁶, for the proposed generating system as configured for the Site.
- CARB distributed generation certification

Or,

- Emission engineering calculations for the proposed generating system as configured for the Site.

Conversion of emissions concentration (ppm) to production based emissions rates (lb/MWh) shall use the method found in Appendix C of this handbook.¹⁷

In addition, the application must include a Permit to Operate issued for the Project from the local air district or air quality authority as part of the Incentive Claim documentation.

2.5.9.2 Fossil Fuel Combustion Emission Credits

Level 3 microturbine, internal combustion engine and gas turbine Projects that do not meet the applicable NOx emission standard (2005 & 2006 = .14 lb/MWh; 2007 = .07 lb/MWh) may receive emission credits for waste heat utilization if the system meets or exceeds the 60% minimum system efficiency standard. The minimum system efficiency shall be measured as useful energy output divided by fuel input in higher heating value. The calculated minimum system efficiency shall be based on 100 percent load. The following formula is to be used to determine the system efficiency.

$$\text{System Efficiency} = (E + T) / F \geq 60\%$$

Where:

E ≡ The generating system's rated electric capacity as defined in Section 2.5.4, converted into equivalent Btu/hr using the factor 3,414 Btu/kWh

T ≡ The generating system's waste heat recovery rate (Btu/hr) at rated capacity.

F ≡ The generating system's Higher Heating Value (HHV) fuel consumption rate (Btu/hr) at rated capacity.

Credit shall be at the rate of one MWh for each 3.4 million British thermal units (Btu) of heat recovered.

The following formula is used to modify the emissions rating for a generating system by giving credit for waste heat utilization.¹⁸

¹⁶ Acceptable test methods include but not limited to CARB Test Method 100 and USEPA Test Method 7.

¹⁷ California Air Resources Board, Guidance for the Permitting of Electric Generation Technologies, Appendix C: Procedure for Converting Emission Data to lb/MW-hr, July 2002.

$$\text{Lb/MWh}_{\text{w/credit}} = \text{Lb/hr}_{\text{EmissionRate}} / (\text{MW}_{\text{Rated}} + \text{MW}_{\text{ProcessHeat}}) \equiv \text{System emissions with thermal credit}$$

Where:

$$\text{Lb/hr}_{\text{EmissionRate}} = \text{Lb/MWh}_{\text{w/o_credit}} \times \text{MW}_{\text{Rated}} \equiv \text{NOx emission rate at the system's rated capacity}$$

$$\text{Lb/MWh}_{\text{w/o_credit}} \equiv \text{System's verified emissions without thermal credits}$$

$$\text{MW}_{\text{Rated}} \equiv \text{System's Rated Capacity as defined in Section 2.5.4.}$$

$$\text{MW}_{\text{ProcessHeat}} = (\text{MMBtu/yr}_{\text{UtilizedWasteHeat}} / 3.4 \text{ MMBtu/MWh}) / \text{EFLH/yr} \equiv \text{Capacity credit for useful thermal energy}$$

$$\text{MMBtu/yr}_{\text{UtilizedWasteHeat}} \equiv \text{Annual utilized waste heat}$$

$$3.4 \text{ MMBtu/MWh} \equiv \text{Heat recovered conversion factor}$$

$$\text{EFLH/yr} \equiv \text{System's annual equivalent full load hours of operation}$$

All assumptions, backup documentation, hand calculations, models (with inputs and outputs) and custom spreadsheets used to develop the forecasts must be included in the documentation. Forecasts based solely on "professional experience" or subjective observation will be rejected. Applications must include a completed Waste Heat/AB1685 spreadsheet, available from the Program Administrators' websites, that calculates the waste heat utilization, minimum system efficiency and emissions requirements.

Example #1: Emissions Credit for 360 kW IC Engine Generator

A 360 kW IC engine generator set is proposed to supply electric power and heat to a furniture manufacturing facility. The system utilizes an intercooler chiller that is rated at 10 kW. Its full load fuel consumption is 4.4 MMBtu/hr LHV (4.8 MMBtu/hr HHV¹⁹) and its full load waste heat recovery rate is 2.6 MMBtu/hr. Source testing documentation for the same generating system make/model and configuration, but from another site, indicate that the NOx emissions from this unit are 0.30 lb/MWh. The generator electric output follows the load of the Host Customers facility, but shuts down when the load falls below 40 kW, the minimum load of the generator. The Host Customer annual peak demand is approximately 400 kW. Waste heat from the generating system is used to deliver hot water for manufacturing process, equipment cleanup and space heating. Detailed analysis of the system and Host Customer load reveals that the system will be generating 1,715,000 kWh/yr at a capacity factor of 56%. The system will produce 12,730 MMBtu/yr of recovered waste heat to serve 12,400 MMBtu/yr of thermal load, however only 8,256 MMBtu/yr of waste heat is actual useful thermal output because of non-coincident load. The system consumes 21,521 MMBtu/yr LHV and 23,673 MMBtu/yr HHV of fuel. Thus -

P.U. Code 218.5 (a)

¹⁸ Emissions credit calculation is based on the California Air Resources Board, Guidance for the Permitting of Electric Generation Technologies, Appendix D: Quantifying CHP Benefits, July 2002.

¹⁹ For natural gas, LHV \approx HHV x 0.9

$$8,255,800,000 \text{ [Btu/yr]} / \{(1,715,000 \text{ [kWh/yr]} \times 3,414 \text{ [Btu/kWh]}) + 8,255,800,000 \text{ [Btu/yr]}\} = 58.5\% \geq 5\% \text{ **Passes**}$$

P.U. Code 218.5 (b)

$$\{(1,715,000 \text{ [kWh/yr]} \times 3,414 \text{ [Btu/kWh]}) + 0.5 \times 8,255,800,000 \text{ Btu/yr}\} / 21,520,800,000 \text{ [Btu/yr]} = 46.4\% \geq 42.5\% \text{ **Passes**}$$

AB 1685 Minimum System Efficiency

$$\{(360 \text{ [kW]} \times 3,414 \text{ [Btu/kWh]}) + 2,598,000 \text{ [Btu/hr]}\} / 4,831,200 \text{ Btu/hr} = 79.2 \geq 60\% \text{ **Passes**}$$

Therefore, the system can take an emissions credit for the useful waste heat.

AB 1685 NOx Emissions Credit

$$\{0.30 \text{ [lb/MWh]} \times .360 \text{ [MW]}\} / \{.360 \text{ [MW]} + (8,256 \text{ [MMBtu/yr]} / 3.4 \text{ [MMBtu/MWh]}) / 4,900 \text{ EFLH/yr}\} = 0.126 \text{ lb/MWh} \leq 0.14 \text{ lb/MWh NOx **Passes**}$$

The Waste Heat/AB1685 spreadsheet, illustrated below, confirms that the calculations are correct. Applications must include a completed Waste Heat/AB1685 spreadsheet available from the Program Administrators' websites.

Applicant:		Date:	
Host Customer:		Application No.:	

Instructions: This spreadsheet calculates the waste heat, system efficiency and emissions eligibility of Level 3-N systems applying to the Self-Generating Incentive Program for incentives. Applicants must provide documentation supporting all inputs including but not limited to system capacity, fuel consumption, waste heat recovery rate, baseline emissions, operating schedule, equivalent full load operating hours and thermal load. See the 2005 SGIP Handbook for details of eligibility and documentation requirements. All yellow cells must be completed by Applicant/Host Customer.

Rated Net Generating Capacity =	360 kW	Full load net continuous rated capacity of the packaged prime mover/generator at ISO conditions.
Ancillary Generating System Loads =	10 kW	Any ancillary equipment loads necessary for the operation of the generator (e.g., fuel compressors, intercooler chillers, etc.)
Fuel Consumption Rate (LHV) =	4,392,000 Btu/hr	Provided by manufacturer or calculated from rated capacity and generator efficiency or heat rate specifications. Based on lower heating value of fuel.
Fuel Consumption Rate (HHV) =	4,831,200 Btu/hr	Provided by manufacturer or calculated from rated capacity and generator efficiency or heat rate specifications. Based on higher heating value of fuel.
Waste Heat Recovery Rate =	2,598,000 Btu/hr	Recoverable heat as specified by manufacturer of generator or waste heat recovery unit at full load conditions. This is not total waste heat of the unit. The value provided should be supported by Generating System specifications (if packaged unit), Waste Heat Recovery System specifications, or engineering analysis of recoverable waste heat.
Generator Emissions =	0.300 lbs/MWh	NOx emissions specifications for the proposed generating system as configured, including emissions controls, for the Host Customer Site at rated conditions. The value provided should be supported by factory testing, other installation source tests or engineering calculations.

Month	Std Hours Per Month (hrs)	Generator Equivalent Full Load Hours per Month (hrs)	Capacity Factor	Generator Electric Output per Month (kWh)	Recovered Waste Heat per Month (Btu)	Thermal Load per Month (Btu)	Useful thermal energy output (Btu)	Fuel Input (LHV Btu)
Jan	744	500	67%	175,000	1,299,000,000	2,000,000,000	1,299,000,000	2,196,000,000
Feb	672	500	74%	175,000	1,299,000,000	2,000,000,000	1,299,000,000	2,196,000,000
Mar	744	500	67%	175,000	1,299,000,000	2,000,000,000	1,299,000,000	2,196,000,000
Apr	720	400	56%	140,000	1,039,200,000	800,000,000	800,000,000	1,756,800,000
May	744	300	40%	105,000	779,400,000	800,000,000	779,400,000	1,317,600,000
Jun	720	500	69%	175,000	1,299,000,000	500,000,000	500,000,000	2,196,000,000
Jul	744	700	94%	245,000	1,818,600,000	500,000,000	500,000,000	3,074,400,000
Aug	744	700	94%	245,000	1,818,600,000	500,000,000	500,000,000	3,074,400,000
Sep	720	500	69%	175,000	1,299,000,000	500,000,000	500,000,000	2,196,000,000
Oct	744	300	40%	105,000	779,400,000	800,000,000	779,400,000	1,317,600,000
Nov	720	0	0%	0	0	1,000,000,000	0	0
Dec	744	0	0%	0	0	1,000,000,000	0	0
Annual Total	8,760	4,900	56%	1,715,000	12,730,200,000	12,400,000,000	8,255,800,000	21,520,800,000

	Eligibility Criteria	Passes?	Reference
AB 1685 Total Efficiency =	79.2% ≥ 60%	Yes	Public Utilities Code 353.2 and 379.6
P.U. Code 218.5 (a) =	58.5% ≥ 5%	Yes	Public Utilities Code 218.5(a) & 18CFR Part 292
P.U. Code 218.5 (b) =	46.4% ≥ 42.5%	Yes	Public Utilities Code 218.5(b) & 18CFR Part 292
NOx Emissions w/o CHP	0.300 ≤ 0.14 lb/MWh	No	
NOx Emissions w/ CHP	0.126 ≤ 0.14 lb/MWh	Yes	Public Utilities Code 379.6 and California Air Resources Board, Guidance for the Permitting of Electric Generation Technologies, Appendix D: Quantifying CHP Benefits, July 2002.

Note: Qualified Level 3 Waste Gas fueled systems are exempt from the emissions standard. See the 2006 SGIP Handbook for Waste Gas emission exemption qualification requirements.

2.5.9.3 Exemptions for Waste Gas Systems

Level 3 microturbine, internal combustion engine and gas turbine systems operating solely on Waste Gas are exempt from the SGIP emission requirements if the local air quality management district or air pollution control district, in issuing a Permit to Operate for the Project, provides in writing a determination that the operation of the Project will produce an onsite net air emissions benefit compared to permitted onsite emissions if the Project does not operate. Note that Waste Gas Systems, though exempt from SGIP emission requirements, still must meet the Waste Heat Utilization Requirement.

2.5.10 Eligibility of Replacement Generation

Installation of new generating systems intended to replace existing on-site generation is allowed only in the following situations.

- A. An eligible generating system may be installed in addition to existing on-site generation if the capacity of the proposed generator(s) meets the maximum size eligibility requirement defined in Section 2.5.6. For fuel cells, microturbines, internal combustion engines and gas turbines, the combined capacity of the proposed and existing generators (excluding any back-up generators) must be no more than the Host Customer's Maximum Site Electric Load for the previous twelve months.
- B. An eligible photovoltaic or wind turbine system may directly replace an existing on-site fossil-fired generating system even if the past 12-months Host Customer's Maximum Site Electric Load is less than the required level as described in Section 2.5.6 of the SGIP Handbook.
- C. An eligible fuel cell, microturbine, internal combustion engine and gas turbine may directly replace an existing cogeneration or non-cogeneration system of equal or larger capacity than the new system, pursuant to eligibility requirements in Section 2.5 of the SGIP Handbook, where the Host Customer can demonstrate that the existing generating system has been out of service for the past 12-months.

2.5.11 Reliability Criteria

Level 3 microturbines, internal combustion engines and gas turbines must meet both of the following reliability requirements:

- 1. The self-generating facility must be designed to operate in power factor mode such that the generator operates between 0.95 power factor lagging and 0.90 power factor leading. This design feature will be verified by reviewing the manufacturer's specifications at the time of application and as part of the field verification visit before incentive payment approval.
- 2. System Owners with facilities sized greater than 200 kW must coordinate the self-generation facility planned maintenance schedule with the Electric Utility. This allows the utility to more accurately schedule load and plan distribution system maintenance. The System Owner will only schedule a facility's planned maintenance between October and March and, if necessary, during off-peak hours and/or weekends during the months of April to September.

2.5.12 Warranty Requirements

Warranty requirements apply to all eligible technologies regardless of length of commercial availability. System Owners are required to fulfill the warranty requirements described below in the following sequence:

1. Utilize equipment warranties, which come standard with the purchase of the system.
2. If the standard equipment warranty for any major system component is of insufficient duration to meet the requirement, the customer must purchase, if one is available, an extended warranty to bridge any gap in duration, which may exist.
3. Then, and only if an application can demonstrate that a standard and/or extended warranty combination is unavailable to meet the warranty requirement – OR if the extended warranty requires the purchase of a maintenance contract – the System Owner is to enter into a maintenance contract as a substitute measure.

The System Owner must provide proof of warranty (and/or maintenance contract), and specify the warranty start and end dates on the Reservation Confirmation and Incentive Claim Form.

2.5.12.1 Photovoltaic, Wind Turbine & Fuel Cell System Warranty Requirements

Photovoltaic, wind turbine and fuel cell systems must be covered by a minimum five-year warranty. The warranty must cover all of the major components of the generating system that are eligible for the incentive, to protect against breakdown or degradation in electrical output of more than ten percent from their originally rated electrical output. The warranty shall cover the full cost of repair or replacement of defective components or systems, including coverage for labor costs to remove and reinstall defective components or systems.

2.5.12.2 Microturbine, Internal Combustion Engine & Gas Turbine System Warranty and/or Maintenance Requirements

Microturbine, internal combustion engine and gas turbine systems must be covered by a warranty of not less than three years. The warranty must cover the major mechanical and electrical components of the generating system that are eligible for the incentive to protect against breakdown. The warranty shall cover the full cost of repair or replacement of defective components or systems, including coverage for labor costs to remove and reinstall defective components or systems. For those systems not already covered by an appropriate term warranty, the customer must purchase an extended warranty from the manufacturer or vendor covering the unwarranted period up to the three-year warranty requirement. The extended warranty must cover the major electrical and mechanical components of the generating system that are eligible for the incentive to protect against breakdown. The major generating system components include the generator set, primary heat recovery system and Renewable Fuel gas cleanup equipment. For those cases where an extended warranty is not available, the customer must purchase a maintenance contract, providing equivalent coverage as the required warranty.

2.5.13 Interconnection to the Utility Distribution System

Connection to, and parallel operation with, the Electric Utility distribution system is required for all self-generation systems as a condition of receiving incentives under the SGIP. The SGIP Host Customer, or their designate, must also separately submit an application and enter into a contract with their local Electric Utility for connection to the utility system. Proof of interconnection and parallel operation is required prior to receiving an incentive payment. Refer to Section 5.1 of this handbook for information on how to apply to the utility for interconnection.

2.5.14 Permanent Installation

Equipment installed under the SGIP is intended to be in place for the duration of its useful life. Only permanently installed systems are eligible for incentives. This means that the generating system must demonstrate to the satisfaction of the Program Administrator adequate assurances of both physical and contractual permanence prior to receiving an incentive.

Physical permanence is to be demonstrated by electrical, thermal and fuel connections in accordance with industry practice for permanently installed equipment and be secured to a permanent surface (e.g. foundation). Any indication of portability, including but not limited to: temporary structures, quick disconnects, unsecured equipment, wheels, carrying handles, dolly, trailer or platform will deem the system ineligible.

Contractual permanence, **corresponding to a minimum of twice the applicable warranty period**, is to be demonstrated as follows:

- System Owner agrees to notify the Program Administrator in writing a minimum of 60 days prior to any change in either the Site location of the generation system, or change in ownership of the generation system, if the change(s) takes place within twice the applicable warranty period.
- All agreements involving the generation system receiving an incentive are to be provided to the Program Administrator for review as soon as they become available (e.g., at the Proof of Project Advancement stage, or the Incentive Claim stage at the latest). These agreements include, but not limited to system purchase and installation agreements, warranties, leases, energy or solar services agreements, energy savings guarantees and system performance guarantees.
- An additional agreement between the System Owner and the Program Administrator may be required, at the Program Administrators' discretion, in order to safeguard against the possibility of early removal and relocation of the generation system. This additional agreement, if required, must be negotiated to the satisfaction of the Program Administrator in order to satisfy this requirement.

2.5.15 New Equipment, Not Pilot or Demonstration Systems

Commercially available factory new generating equipment is eligible for incentives. Rebuilt, refurbished or relocated equipment is not eligible to receive SGIP incentives. Generating systems that utilize new technologies that are critical to its operation must have at least one year of documented commercial availability to be eligible, or meet the requirements of Section 2.5.15.1. "Commercially available" means that the major generating system components (e.g. the generator set, primary heat recovery system and Level 2 gas cleanup equipment) are acquired through conventional procurement channels, installed and operational at a Site. Commercially available does not include field demonstrations for proof-of-concept operation of experimental or non-conventional systems partially or completely paid by research and development funds.

2.5.15.1 Alternative Criteria for Generating System Eligibility – Third Party Certification

Generating systems consisting of or utilizing new technologies may be eligible for the SGIP if certification is obtained from a nationally recognized testing laboratory indicating that the technology meets the safety and/or performance requirements of a nationally recognized standard. Equipment manufacturers seeking eligibility through these criteria shall submit a written request via the PMG to the SGIP Working Group for consideration, along with the proposed standards for certification.

2.5.15.2 CEC's Emerging Renewables Program – Renewable Equipment Eligibility

Photovoltaic, wind turbine and fuel cell equipment eligible for use in the CEC's Emerging Renewables Program are eligible for the SGIP under Section 2.5.15. A list of CEC eligible equipment is available online at: <http://www.consumerenergycenter.org/erprebate>.

2.6 Eligible Fuels

Eligible fuels for eligible SGIP generating technologies are classified as renewable, non-renewable and Waste Gas. Each type of eligible fuel is described below.

2.6.1 Renewable Fuels

A Renewable Fuel, for the purposes of determining whether a proposed Project qualifies for Level 2 incentives, is a non-fossil fuel resource other than those defined as conventional in Section 2805 of the Public Utilities Code that can be categorized as one of the following: solar, wind, gas derived from biomass, digester gas, or landfill gas. A facility utilizing a Renewable Fuel may not use more than 25 percent fossil fuel annually, as determined on a total energy input basis for the calendar year. In addition, applications for Level 2 Projects are required to:

- Demonstrate the availability of an adequate average flow rate of Renewable Fuel, for the duration of the required warranty period (Level 2 fuel cells is 5 years and all other Level 2 technologies are 3 years), to produce electricity at the unit's full rated capacity, or an appropriate de-rated

operating capacity²⁰ based on the annual average available Renewable Fuel resource flow rate including allowable Non-Renewable Fuel supplement. Evidence that an adequate Renewable Fuel resource exists will be verified during the field verification visit prior to approval of the incentive. Units whose annual fuel consumption exceeds the available Renewable Fuel plus the allowable Non-Renewable Fuel supplement will have the incentive based upon on the operating capacity resulting from the average annual available Renewable Fuel flow rate, including allowable Non-Renewable fuel flow rate. Increasing an existing generator's Non-Renewable Fuel consumption to increase the available Renewable Fuel resource for a new SGIP proposed generator is not allowed.

- Submit an equipment purchase order that indicates the fuel cleanup equipment as a separate invoice item.
- Provide a signed affidavit stating that the unit will comply with the SGIP Renewable Fuel requirements. The length of this commitment shall be the same as the equipment warranty requirement discussed above for each incentive category.

Level 2 incentives shall be subject to refund to the Program Administrator by the recipient if it is determined that the Project operates on more than 25% fossil fuel, on an annual basis, before the required warranty period expires.

2.6.2 Non-Renewable Fuels

Non-Renewable fuels for Level 3 technologies include fossil fuels and synthetic fuels.

For the SGIP, eligible fossil fuels include gasoline, natural gas and propane. Diesel fuel (including biodiesel and other fuels that can be interchanged with diesel fuel) is explicitly ineligible in the SGIP.

Synthetic fuels are fuels derived from materials that are not Renewable Fuels (see Section 2.6.1) or fossil fuels. Eligible synthetic fuels include, but are not limited to, the direct use or synthesis of fuels from sewage sludge, industrial waste, medical waste or hazardous waste.

2.6.3 Waste Gas Fuels

Waste Gas fuels used for Level 3 technologies are strictly defined as natural gas that is generated as a byproduct of petroleum production operations and is not eligible for delivery to the utility pipeline system.

In order to be eligible for Waste Gas exemptions, applications must:

- Demonstrate the availability of an adequate average flow rate of Waste Gas fuel, for the duration of the required warranty period (3 years), to produce electricity at the unit's full rated capacity, or

²⁰ "De-rated capacity" is the generating system average capacity based on available Renewable Fuel resource and is the capacity used to determine the incentive amount.

an appropriate de-rated capacity.²¹ Information shall be submitted with the SGIP application and will be verified during the field verification visit prior to approval of the incentive.

- The application must include an affidavit or other form of proof, that specifies that the Project shall be operated solely (100%) on Waste Gas for the duration of the required warranty period (3 years).
- The air quality management district or air pollution control district, in issuing a Permit to Operate for the Project, must provide a written determination that operation of the Project will produce an on-site net air emissions benefit.

Incentives paid for Level 3 Waste Gas fuel systems shall be subject to refund to the Program Administrator by the recipient if it is determined that the Project does not operate on Waste Gas for at least the required warranty period.

2.7 Incentives from Other Sources

Projects receiving rebates or incentives based on future performance of the Project are ineligible for SGIP participation. See Section 3.3.2 for treatment of incentives from other sources in calculating the SGIP incentives.

²¹ "De-rated capacity" is the rated capacity on Waste Gas fuels and is the capacity used to determine the incentive amount.

3 INCENTIVES

Annual incentive budgets for Program Year 2006 authorized by the CPUC for each Program Administrator are as follows:

Pacific Gas and Electric Company	\$172,800,000
Southern California Edison Company	\$121,050,000
Southern California Gas Company	\$39,600,000
San Diego Regional Energy Office	\$49,050,000

One-third of the \$112,500,000 SGIP incentive budget is allocated equally to each of the self-generation categories (Levels 1, 2 and 3). For 2006, the CPUC allocated an additional \$270,000,000 of incentives for solar generating technologies.²² Although the Program Administrator may move funds from the non-renewable category to renewable categories, the Program Administrator must seek approval from the CPUC through an advice letter prior to shifting funds from renewable categories into the non-renewable category.

3.1 Incentive Levels

The SGIP provides a one-time incentive payment to help reduce the cost of installing self-generation equipment. The incentive levels for the three categories of self-generation technologies are provided below in Table 3-1.

Check the Program Administrators' websites for current incentive levels.

²² CPUC Decision 05-12-044, December 15, 2005

Table 3-1 Incentive Levels for Eligible Technologies

Incentive Levels	Eligible Technologies	Incentive Offered (\$/Watt)	Minimum System Size	Maximum System Size	Maximum Incentive Size
Level 1 Solar	Photovoltaics	\$2.80/W \$2.50/W @ 50 MW \$2.25/W @ 120 MW	30 kW	5 MW	1 MW
Level 2 Renewable Non-Solar	Wind turbines	\$1.50/W	30 kW	5 MW	1 MW
	Renewable fuel cells	\$4.50/W			
	Renewable fuel microturbines and small gas turbines	\$1.30/W	None		
	Renewable fuel internal combustion engines and large gas turbines ²³	\$1.00/W	None		
Level 3 Non-Renewable Non-Solar	Non-Renewable fuel cells	\$2.50/W	None	5 MW	1 MW
	Non-Renewable & Waste Gas fuel microturbines and small gas turbines	\$0.80/W			
	Non-Renewable & Waste Gas fuel internal combustion engines and large gas turbines	\$0.60/W			

3.2 Incentive Reduction Trigger for Photovoltaic Technologies

As part of Decision 06-01-024 “Interim Order Adopting Policies and Funding for the California Solar Initiative”, issued January 12, 2006, the CPUC adopted an automatic schedule to reduce photovoltaic incentives each year or faster if program participation exceeds a pre-determined capacity level.

As shown in Table 3-2 below, after 50 MW of conditional reservations are issued, the incentive will be reduced to \$2.50. If an additional 70 MW of conditional reservations are issued in 2006, the incentive will be reduced to \$2.25.

Table 3-2: Triggers for Reductions in Rebate Levels

Incremental MW	Incentive Rate (\$/watt)
	2.80
50	2.50
70	2.25

²³ Large gas turbines are ≥ 1 MW in capacity. Small gas turbines and microturbines are <1 MW in capacity.

To assist Host Customers, System Owners and Applicants each Program Administrators' websites provides a total number of statewide conditional reservations for photovoltaic applications.

3.3 Incentive Limitations

Incentive amounts and Project eligibility for the SGIP are limited by a number of factors, including:

- Total eligible Project costs
- Other Incentives or Rebates
- Project capacity size & Host Customer site limitations

3.3.1 Total Eligible Project Costs

The maximum possible incentive payment for each system is the system size (up to 1,000 kW) multiplied by the applicable dollar per kW incentive rate. No Project can receive total incentives (SGIP and other incentives combined) that exceed total eligible Project costs.²⁴ Submittal of Project cost details is required to report total eligible Project costs and to ensure that total incentives do not exceed out of pocket expenses for the System Owner. See Appendix A for eligible cost items for photovoltaic systems and Appendix B for a description of cost elements to be included in the total eligible Project cost. Total eligible Project costs cover the generating system and its ancillary equipment. Equipment and other costs outside of the Project envelope defined in Appendix A & B are considered ineligible Project costs, but also must be reported. For large multifaceted Projects where the generating system costs are embedded, applications must include a prorated estimate of the total eligible costs for the generating system. Applications must include the Project cost breakdown worksheet available from the Program Administrators' websites.

3.3.2 Other Incentives or Rebates

Customers may not receive SGIP incentives for the same self-generation equipment from more than one Program Administrator (e.g., PG&E and SoCalGas, SCE and SoCalGas, etc.). Projects receiving incentives from the CEC Emerging Renewables Program or any performance based incentive (PBI) program, including those offered under the CEC pilot PBI, are ineligible for SGIP.

For Projects receiving self-generating incentives under other programs, the SGIP incentive may be reduced, depending on the source of the other incentive, effectively allowing only part of the other program incentive in addition to the SGIP incentive. For Projects that receive "other incentives" funded by California investor owned utility (IOU) ratepayers (e.g., Utility or CEC Public Goods Charge programs,

²⁴ "Total eligible Project costs" include the generator equipment, ancillary equipment and installations labor/materials. "Total eligible Project costs" are equivalent to "eligible Project costs" which were used in previous SGIP program years to calculate incentive amounts. See Appendix C for a list of "total eligible Project costs".

etc.), the SGIP incentive is discounted by the amount of the other incentive. For Projects that receive “other incentives” funded by non-IOU ratepayers (LADWP, SMUD, etc.) the SGIP incentive is discounted by 50% of the other incentive. For Projects that receive “other incentives” funded from other sources than utility ratepayers (federal & state grants, air district grants, tax credits, etc.) no adjustment is made to the SGIP incentive.

In no event may the combined incentives received from SGIP and other funding sources exceed the total eligible Project cost. Host Customers, Applicants and System Owners are required to disclose information about all other incentives, including for equipment or systems ancillary to the generating system, they may receive including post-installation incentives or rebates. Program Administrators will enter applications into a statewide database that will permit universal tracking of applications for this and other programs, such as, but not limited to the CEC’s Emerging Renewables Program and pilot Performance-Based Incentive Program.

The SGIP incentives will be reduced by the percent of other program incentives depending on the funding source of the other incentives as described in the following table.

Table 3-3 Percent of “Other Incentive” Adjustment to SGIP

Other Incentive Funding Source	Pct. Of Other Incentive Discount of SGIP Incentive
Investor Owned Utility Ratepayer	100%
Non-IOU Ratepayer	50%
Non-Ratepayer	0%

A sample calculation of a SGIP Project with incentives from the SGIP and a second funding source for various types of eligible 1 MW systems is illustrated in Table 3-4.

Table 3-4 Accounting for Other Incentives

(A)	(B)	(C)	(D)	(E)	(F) = (E) + (C)
System Type	SGIP \$/Watt Rebate Amount Before Accounting for Other Rebates	“Other Rebate” Amount	Source and Percentage of “Other Rebate” Adjustment to SGIP Incentive	SGIP Rebate Amount After Adjusting for Other Rebates \$/Watt	Total Customer Rebate Amount \$/Watt
PV	\$2.80/W	\$1.00/W	Public Interest Energy Research (PIER) 100%	$\$2.80/W - [\$1.00 * 1.00]$ = \$1.80/W	$\$1.80/W + \$1.00/W$ = \$2.80/W
PV	\$2.80/W	\$1.00/W	Municipal Utility Solar Incentive Program 50%	$\$2.80/W - [\$1.00 * 0.50]$ = \$2.30/W	$\$2.30/W + \$1.00/W$ = \$3.30/W
Fuel Cell (on NG)	\$2.50/W	\$1.00/W	Federal Government Grant 0%	$\$2.50/W - [\$1.00 * 0.00]$ = \$2.50/W	$\$2.50/W + \$1.00/W$ = \$3.50/W

3.3.3 Site and Host Customer Limitations

There are restrictions on the amount of incentive funding a Host Customer can reserve and receive. Host Customers can reserve up to 1 MW of maximum incentive funding for a single Site for the SGIP’s duration. In addition, a 5 MW Project size limit per Host Customer Site is in force for all Projects.

3.4 Calculating the Incentive

Incentives for a proposed system are calculated by multiplying the capacity of the generating system by the incentive rate for the appropriate incentive Level (1, 2 or 3) and technology. If the Project is receiving other incentives, a portion of those incentives must be subtracted from the maximum SGIP incentive calculated based on capacity. The remaining amount is the incentive that will be provided by SGIP. An SGIP Incentive Calculation Worksheet is available on each Program Administrator’s website.

No Project can receive incentive payments that exceed the total eligible cost of the generating system.

Example #2: Single System Level 3 Microturbine Technology

A Host Customer proposes to install a 75 kW natural gas fueled microturbine with waste heat recovery at a customer Site to provide a portion of the facilities’ peak (maximum) electric demand. There are no other incentives included. The Level 3 incentive for this technology is \$0.80/Watt (or \$800/kW) and the Project cost is \$225,000 (\$3.00/Watt). Multiplying the Level 3 incentive by the capacity of the generation results in an incentive of \$60,000, this does not exceed the out-of-pocket expense for the system.

Example #3: Incentive Calculation for System Receiving Incentives from Other Programs

A Host Customer is installing a 1.0 MW fuel cell, operating on Renewable Fuel, which is estimated to cost \$10 million (\$10/Watt). The Project received a rebate of 20% of the Project costs (\$2 million) from an IOU Ratepayer funded program. The Level 2 SGIP incentive for this technology is \$4.50/watt. Because the other incentive is IOU ratepayer funded, the SGIP incentive is adjusted. In addition, the out-of-pocket expense of the System Owner must not be less than zero. The out-of-pocket expense of the system is the total eligible Project cost less any incentives including SGIP. Under the SGIP, this Project would be eligible for an incentive of \$2.5 million as follows:

$$\text{Maximum SGIP Incentive based on System Size} = 1,000,000 \text{ W} \times \$4.50 / \text{W} = \$4,500,000$$

$$\text{Adjusted SGIP Incentive} = \$4,500,000 - 1.0 \times \$2,000,000 = \$2,500,000$$

$$\text{Total Incentive} = \$2,500,000 + \$2,000,000 = \$4,500,000$$

Since the total Incentive (\$4,500,000) is lower than the total eligible Project cost of \$10 million the SGIP incentive is \$2,500,000.

3.4.1 Level 2 (Renewable Fuel) Incentive Calculation

For fuel cells, microturbines, internal combustion engines and gas turbines on Renewable Fuels an incentive will be paid based on the operating capacity resulting from the average annual available Renewable Fuel flow rate, including allowable Non-Renewable fuel flow rate. The nameplate rated capacity of the generator must not exceed the peak electric load at the site.

3.4.2 Incentive for Systems with Output Capacity above 1 MW

For Projects with capacities greater than 1 MW, but less than or equal to 5 MW the incentive is calculated by multiplying the 1,000 kW, the maximum allowed incentive capacity of the generating system, by the incentive rate for the appropriate incentive Level (1, 2 or 3) and technology. If these Projects are also receiving self-generating incentives from other programs, the SGIP incentive may be reduced, depending on the source of the other incentive, to effectively allow only part of the other program incentive in addition to the SGIP incentive (See Section 3.3.2). The remaining amount is the incentive that will be provided by SGIP.

Example #4: Incentive Calculation for Systems with Output Capacity above 1.0 MW and Receiving Incentives from Other Programs

A customer is installing a 1.2 MW fuel cell, operating on natural gas, which is estimated to cost \$7 million. The Level 3 incentives for this technology are \$2.50/watt for the first 1.0 MW. The Project also received a \$1 million rebate from a Federal taxpayer funded program. Under the SGIP, the incentive would be calculated as follows:

$$\text{Maximum SGIP Incentive} = 1,000,000 \text{ Watt} \times \$2.50/\text{Watt} = \$2,500,000$$

$$\text{Adjusted SGIP Incentive} = \$2,500,000 - 0.0 \times \$1,000,000 = \$2,500,000$$

$$\text{Total Incentive} = \$2,500,000 + \$1,000,000 = \$3,500,000$$

Since total incentive of \$3,500,000 is lower than the total eligible Project cost of \$7 million the SGIP incentive is \$2,500,000.

3.5 Hybrid System Incentives

Program participants can apply for incentives for multiple types of generating technologies installed at one Site. The program defines these as “Hybrid Systems”. An example of this situation would be photovoltaics and natural gas fuel cells, or photovoltaics and a wind turbine, combined at one Site. As with single technology systems, hybrid systems must meet all eligibility requirements set forth by this program including, but not limited to, size constraints, waste heat utilization, emissions and reliability criteria.

The total SGIP hybrid incentive is the sum of the incentive for each type of technology less other incentives. When calculating the total eligible incentive for a hybrid system, the incentives are to be calculated sequentially until the 1 MW limit is reached, with the highest incentive technology portion calculated first, then the next highest incentive technology (based on whatever capacity remains under 1 MW after that claimed for the first technology) and so forth. For multiple technologies within a single Incentive Level, the incentives are calculated in the order in which they appear in Table 3-1, from top to bottom.

Table 3-4 provides an example of the incentive calculation for an example hybrid system that is greater than 1 MW without other incentives. The system consists of a 650 kW Level 1 photovoltaic and 600 kW Level 3 IC engine technologies. As shown below, the Level 1 photovoltaic technology receives the full incentive of \$1,820,000. The Level 3 IC engine technology receives a reduced incentive amount of \$210,000 based on remaining 350 kW of capacity.

Table 3-5 Example 5: Hybrid System Cost Calculation

	Level 1 Solar	Level 2 Non-Solar Renewable	Level 3 Non- Renewable	Hybrid System Total
1. Incentive Rate (\$/Watt)	<u>\$2.80/W PV</u> (A)	\$4.50/W fuel cell \$1.00/W Wind \$1.30/W MT \$1.00/W IC Engine, gas turbine (B)	\$2.50/W Fuel Cell \$0.80/W MT <u>\$0.60/W IC Engine, gas turbine</u> (C)	
2. Technology Capacity (kW)	<u>650 kW</u> (D)	<u>0 kW</u> (E)	<u>600kW</u> (F)	<u>1,250 kW</u> (G) D + E + F
3. Incented Capacity (kW)	<u>650 kW</u> (H) H=D	<u>0 kW</u> (I) I=E or I=1,000-H (<i>whichever is less</i>)	<u>350 kW</u> (J) J=F or J=1,000-H-I (<i>whichever is less</i>)	<u>1,000 kW</u> (N) H+I+J
4. Total SGIP hybrid Incentive Calculation	<u>\$1,820,000</u> (O) A x H 650,000 W x \$2.80/W	<u>\$0</u> (P) B x I	<u>\$210,000</u> (Q) C x J 350,000 W x \$0.60/W	<u>\$2,030,000</u> O + P + Q

4 APPLICATION PROCESS

Incomplete or incorrect applications will be returned, so it saves time to follow the instructions carefully. Applicants may contact the Program Administrator for assistance in completing their applications. See Section 7 for contact information for each of the Program Administrators.

4.1 Overview of the Application Process

To receive an incentive payment through the SGIP, Applicants must submit the appropriate application form and supplemental materials at specific milestones. While the overall application process is identical for all three incentive levels (See Table 2-1), there are a few minor differences in the required attachments for each. The overall application process and timeline for documentation due dates are illustrated in Figure 4-1.

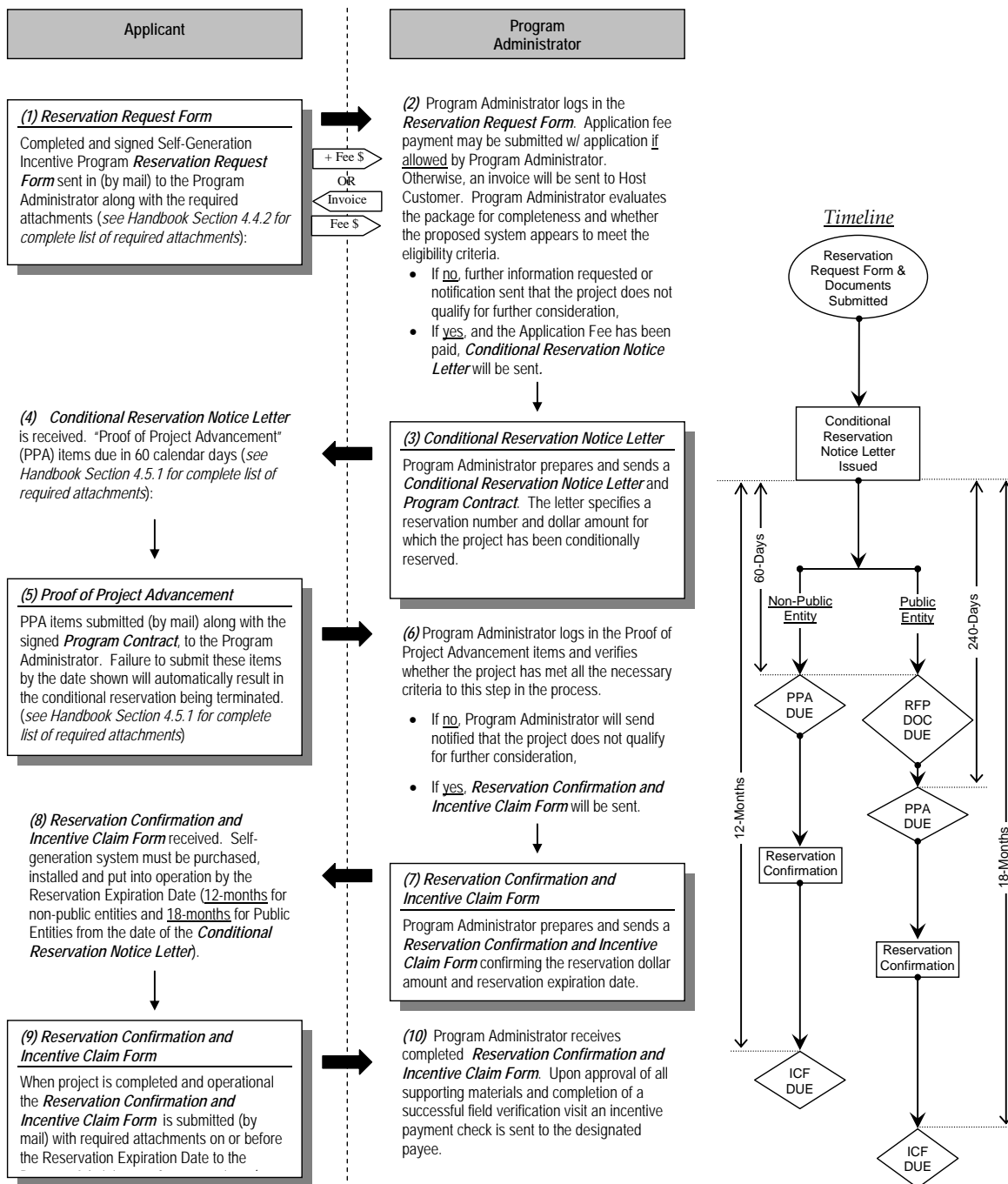

Figure 4-1 SGIP Application Process Overview

4.2 Assignment of SGIP Application Rights & Responsibilities

The Host Customer is the exclusive reservation holder. Neither the Host Customer nor the System Owner may assign its rights or delegate its duties without prior written consent of the Program Administrator, which consent shall not be unreasonably withheld or delayed. The System Owner shall

assign its rights or delegate its duties only with the prior written consent of the Host Customer, except in connection with the sale or merger of a substantial portion of its assets. Both the Host Customer and the System Owner, if different than the Host Customer, must provide assurance of Project success, if assigned, by providing any additional information requested by Program Administrator.

4.3 Application Fee

In addition to the Reservation Request Form and Required Attachments, per SGIP Handbook Section 4.4.2, Host Customers are also required to submit an Application Fee.

The Application Fee is 0.5% of the unadjusted requested SGIP Incentive Amount. Application Fees will be rounded to the nearest dollar amount. The Application Fee will be implemented as follows:

- At their discretion, Program Administrators may allow the Application Fee to be sent in with the Reservation Request Form and Required Attachments. Refer to the Reservation Request Form Checklist on the Program Administrators web site to determine if this is allowed. Program Administrators will accept payments from either the Host Customer, or the System Owner, the Applicant, or a third party on behalf of the Host Customer for a particular Project; however, any refunded Application Fees shall only be paid to the Host Customer.
- If the Application Fee is not submitted with the Reservation Request Form and Required Attachments, or if the Application Fee amount submitted is incorrect, the Program Administrators will invoice the Host Customer (Utility Customer of Record) after review of the Reservation Request Form package.
- The Host Customer will have 30 days to submit payment in order to retain their position on the Level 1 waiting list and/or activate the Reservation Request. Program Administrators will also accept payments from the System Owner, the Applicant, or a third party on behalf of the Host Customer for a particular Project; however, any refunded Application Fees shall only be paid to the Host Customer. The payment must reference the Project application number.
- Program Administrators will only accept Application Fees in the form of a check. Cash, credit cards, money orders, promissory notes, etc. will not be accepted.
- Returned checks will result in the Program Administrator rejecting the Reservation Request from SGIP.
- Failure to submit payment within 30 days will result in the cancellation of the Reservation Request.
- If a Project is withdrawn from a Wait List prior to receiving a Conditional Reservation, the Application Fee will be returned in full to the Host Customer.
- If upon eligibility screening, the Project does not qualify for a Conditional Reservation, the Application Fee will be returned in full to the Host Customer.

- Once a Conditional Reservation is granted and the Project is cancelled or withdrawn by the Host Customer, the Application Fee will be forfeited.
- Once a Conditional Reservation is granted and the Project is rejected by the Program Administrator for failing to meet Proof of Project Advancement or Reservation Expiration Date requirements, the Application Fee will be forfeited.
- Application Fees will be linked to reservation numbers, not to the Project sites; therefore, the Project must be completed under the same reservation number as the one linked to the Application Fee. If a Project reservation is allowed to lapse, and the Project is later built under a new reservation, the Application Fee for the previous reservation will be forfeited.
- If a Reservation Request and Application Fee are submitted for the same Project to two different Program Administrators (example: one to SoCalGas and one to SCE), and receives a Conditional Reservation from one of the Program Administrators, the Applicant has 14 calendar days to submit in writing a request to withdraw the Reservation Request from the second Program Administrator without losing the second Application Fee. Upon receipt of this request, the Application Fee shall be returned to the Host Customer. If the second Reservation Request is not withdrawn the within 14 calendar days, the Application Fee submitted with that Reservation Request would be forfeited.
- If a Conditional Reservation is granted and the \$/W rebate level has been reduced (due to Commission directive, declining rebate structure, etc.), the Applicant and Host Customer will be notified and given 14 calendar days to submit in writing a request to withdraw their Reservation Request without losing their Application Fee. Upon receipt of a request, the Application Fee shall be returned to the Host Customer. If the Reservation Request application is not withdrawn the within 14 calendar days, the Application Fee submitted would be forfeited.
- Application Fees will be retained until the completion of the proposed SGIP Project and will not be adjusted due to changes in system size and/or changes in \$/Watt rebate level.
- Upon completion and verification of the installed SGIP Project and incentive payment, the Application Fee will be returned in full to the Host Customer.
- No interest will be paid on Application Fees.
- All forfeited Application Fees will be re-allocated to the Program Administrator's incentive budget.
- If a Project that has met Proof of Project Advancement and received a "Confirmed Reservation and Incentive Claim Form" from the Program Administrator is withdrawn due to extenuating circumstances beyond the Host Customer's control, the Application Fee may be returned pending Program Administrator and Working Group approval.

- For 2005, waiting list applications that are cancelled by the Host Customer after December 15, 2005, and prior to receiving a Conditional Notice Letter, reservation the application fee will be refunded.

4.4 Reserving an Incentive

Applicants can reserve an incentive amount for up to 12-months for non-public entities and 18-months for Public Entities. Once a Reservation Request Form and application package is determined to be complete and eligible, the Program Administrator will (depending upon funding availability) conditionally reserve a specific dollar amount for a specified Project system size. The initial conditional reservation is only valid for 60 calendar days. Non-public entities, within 60 calendar days of the date the Conditional Reservation Letter, must satisfy all Proof of Project Advancement criteria, including returning a signed SGIP Contract. Public Entities, within 60 calendar days of the date the Conditional Reservation Letter, must submit a copy of the issued request for proposal (RFP or equivalent) for purchase or installation of the generating system and within 240 calendar days of the date the Conditional Reservation Letter satisfy all Proof of Project Advancement criteria, including returning a signed SGIP Contract. Once the application has successfully met Proof of Project Advancement requirements the Program Administrator will issue a Reservation Confirmation and Incentive Claim Form with a Reservation Expiration Date of 12-months from the date of the initial Conditional Reservation Notice Letter for non-public entities and 18-months from the date of the initial Conditional Reservation Notice Letter for Public Entities.

SGIP funds are available on a first-come, first-served basis throughout the calendar year (January 1 through December 31). Reservations received after total funds have been committed for a calendar year will be placed on a waiting list in the event that more funding becomes available (either through an approved shift in funds between incentive levels or Project cancellations).

4.4.1 Reservation Request Form

To reserve a specified incentive amount, a Reservation Request Form must be submitted and all required documentation attachments.

Applications that include technologies from two or more different incentive levels (hybrid Projects) must include one Reservation Request Form for each technology in the Project. For more information on Hybrid Systems, see Sections 2.5.2 and 3.5.

Reservation Request Forms and instructions on completing these forms can be obtained by calling or visiting the website of the Program Administrator in your area.

4.4.2 Required Attachments

In addition to a completed Reservation Request Form, with original signatures of Applicant and Host Customer, all applications (Levels 1, 2 and 3) a must provide a copy of the following:

Table 4-1 Reservation Request Application Attachments

Required Materials	Photovoltaics & Wind Turbines	Renewable Fueled Fuel Cells, IC Engines, Gas Turbines & Microturbines	Non-Renewable Fueled Fuel Cells	Non-Renewable and Waste Gas Fueled IC Engines, Gas Turbines & Microturbines
1. Completed Reservation Request Application Checklist	✓	✓	✓	✓
2. Completed Reservation Request Application w/ Original Signatures	✓	✓	✓	✓
3. Proof of Utility Service	✓	✓	✓	✓
4. Electrical System Sizing Documentation	✓	✓	✓	✓
5. System Description Worksheet	✓	✓	✓	✓
6. Incentive Calculation Worksheet	✓	✓	✓	✓
7. Description of other Funding Sources	✓	✓	✓	✓
8. AB1407 Public Entity Certification	✓ Public Entities Requesting Solar Incentives Only	N/A	N/A	N/A
9. Proof of Adequate Renewable Fuel Resource	N/A	✓	N/A	N/A
10. Waste Heat Recovery PUC 218.5 Calculation	N/A	N/A	✓	✓
• Generator & Thermal System Description	N/A	N/A	✓	✓
• Forecast of Generator Electric Output	N/A	N/A	✓	✓
• Forecast of Generator Thermal Output	N/A	N/A	✓	✓
• Forecast of Generator Fuel Consumption	N/A	N/A	✓	✓
• Forecast of Thermal Load Magnitude	N/A	N/A	✓	✓
• Forecast of Useful Thermal Output	N/A	N/A	✓	✓
11. Proof of Power Factor Eligibility	N/A	N/A	N/A	✓

Required Materials	Photovoltaics & Wind Turbines	Renewable Fueled Fuel Cells, IC Engines, Gas Turbines & Microturbines	Non-Renewable Fueled Fuel Cells	Non-Renewable and Waste Gas Fueled IC Engines, Gas Turbines & Microturbines
12. Proof of NOx Emissions Qualifications	N/A	N/A	N/A	✓
• Minimum 60% System Efficiency Calculation	N/A	N/A	N/A	✓
• Emissions Credits Calculation (if applicable)	N/A	N/A	N/A	✓
13. Proof of Adequate Waste Gas Fuel	N/A	N/A	N/A	✓ Waste Gas Fuel Only

- ❖ **Reservation Request Application Checklist** – All Reservation Request Application submittals must be accompanied by a completed and signed checklist.
- ❖ **Reservation Request Form** – A completed Reservation Request Form must be submitted with all applications. It must be completed and signed by representatives with signature authority for both the System Owner and Host Customer. Only applications with the necessary original signatures on the same form will be accepted.
- ❖ **Proof of Utility Service** – Eligibility requirements restrict participation in the SGIP to customers who are located in PG&E, SCE, SoCalGas or SDG&E service territories and physically connected to the Electric Utility transmission and distribution system. All applications must include a copy of a recent electric or gas utility bill. For new construction, the Host Customer must receive confirmation from the serving utility that their Site is within the Program Administrator’s service territory.
- ❖ **Electrical System Sizing Documentation** – To confirm that participating distributed generation systems will not exceed the capacity of the Host Customer’s previous 12-month peak (maximum) electrical demand, all applications must include a copy of the data and calculations used to determine system size.
- ❖ **System Description Worksheet** – All applications are required to include a completed System Description Worksheet, available from Program Administrator’s website.
- ❖ **Incentive Calculation Worksheet** – All applications are required to include a completed Incentive Calculation Worksheet, available from Program Administrator’s website. The Incentive Calculation Worksheet calculates the incentive and adjusts for other incentives and Project cost.
- ❖ **Other Funding or Project Assistance Sources** – When applicable, applications must include disclosures of all Project funding and/or Project financial assistance sources that reduce the System Owner’s otherwise out-of-pocket expenses for the Project. Submitted documentation must confirm

funding or financial assistance source and the amount or type of assistance. This funding or assistance (e.g., gifted equipment) may be from any other source, and received before, during or after equipment installation.

- ❖ **AB 1407 Public Entity Certification (Public Entities Only)** – Any Public Entity applying for solar energy incentives under SGIP, must certify that it has voided any existing law, under its authority, that prohibits or restricts the installation or use of a solar energy system in accordance with the requirements set forth in AB 1407. Failure to do so prevents Public Entities from participating in SGIP.
- ❖ **Proof of Adequate Renewable Fuel (Level 2)** – When applicable, applications must include an engineering survey or study confirming the on-site Renewable Fuel (*i.e.*, adequate flow rate) and the generating system’s average capacity during the term of the Project’s required warranty/maintenance period.
- ❖ **Waste Heat Recovery Calculation/Justification (Level 3)** – When applicable, applications must include a generator and thermal system description, generator electric output forecast and thermal output, generator fuel consumption forecast, thermal load magnitude forecast, and useful thermal energy forecast, to demonstrate compliance with the Program’s waste heat utilization requirements (PU Code 218.5). A copy of the engineering calculations, data used, and all assumptions used to demonstrate this system efficiency must also be submitted. See Section 2.5.8 for more information on waste heat recovery.
- ❖ **Power Factor (PF) Specification (Level 3 Microturbines, Internal Combustion Engines & Gas Turbines)** – When applicable, applications must include self-generating facility design specifications and/or manufacturer’s specifications which show that the system will be capable of operating between 0.95 PF lagging and 0.90 PF leading.
- ❖ **Proof of NOx Emission Qualifications (Level 3 Microturbines, Internal Combustion Engines & Gas Turbines Except Waste Gas Fuel Applications)** – When applicable, applications must include documentation (see Section 2.5.9) substantiating that the generator’s NOx emissions are at or below the applicable emission standard. Units that do not pass the emission standard may use emission credits if they meet or exceed the 60% minimum system efficiency.
 - **60% Minimum System Efficiency Specification** – If the application claims emission credits for their waste heat utilization; manufacturer specifications and calculations substantiating that the minimum system efficiency of the generator is equal or greater than 60% must be included. (See Section 2.5.9.2 for details).
 - **Emission Credits** – If the application claims NOx emission credits for their waste heat utilization and they meet or exceed the 60% minimum system efficiency requirement, emission credit

calculation documentation based on the amount of waste heat utilized over a twelve-month period must be provided. (See Section 2.5.9.2 for details)

- ❖ **Proof of Adequate Waste Gas Fuel (Level 3 Microturbines, Internal Combustion Engines & Gas Turbines Waste Gas Fuel Applications Only)** – When applicable, applications must include an engineering survey or study confirming that there is adequate on-site Waste Gas fuel (i.e., adequate flow rate) for continuous operation of the self-generation unit for the term of the Project's required warranty/maintenance period.

4.4.3 Submitting the Reservation Request Form

Once the Reservation Request Form is complete and all the required attachments are secured, Applicants must submit their application package to the Program Administrator. To ensure confirmation of receipt, documentation is to be delivered to the appropriate Program Administrator by certified or overnight mail. No faxed or hand delivered applications will be accepted.

4.4.4 Application Screening

Once received, the Program Administrator will review the application package for completeness and determine eligibility. Applications will also be screened to ensure that the Project has not applied for incentives through other Program Administrators or other state- or government-sponsored incentive programs (e.g., CEC's Emerging Renewables Program).

4.4.5 Incomplete Reservation Requests

If an application is found to require clarification, the Program Administrator will request the information necessary to process that application further. Applicants have 20 calendar days to respond to the requested clarification with the necessary information. If after 20 calendar days, the Applicant has not submitted the requested information the applications will be canceled. Resubmitted application packages will be treated as a new application (i.e., all required documents must be resubmitted) and processed in sequence along with other new applications.

4.4.6 Approved Reservation Request Form

Upon approval by Program Administrator of the reservation request package (Reservation Request Form and required attachments), the Applicant and Host Customer will receive a Conditional Reservation Notice Letter and an SGIP Contract *if* funds are available. Incentive funds are not reserved until the Program Administrator receives all information and documentation required for the Reservation Request Form and the Project is approved.

4.4.7 Waiting List Procedures

If funds are not available for a particular reservation request while a Program Administrator is still accepting new applications it will be assigned a place on a waiting list upon approval of the reservation request package (Reservation Request Form and required attachments). The Applicant and Host

Customer will receive notification that their request is on a waiting list until funding is made available (through budget transfers between categories, and/or other Projects ahead of it dropping out), or it is withdrawn or cancelled. A place on the waiting list is not secured until the Program Administrator receives all information and documentation required with the Reservation Request Form and the Project is determined to meet all eligibility requirements. When applications are placed on the waiting list, the procedures below will be followed.

- Waiting list applications will be given priority based on the date received, although the incentive amount is based on the date all information is received.
- All waiting list applications must submit their respective Application Fee to maintain their position on the waiting list.
- All waiting list applications will be reviewed for completeness and eligibility. Any deficiencies must be corrected to maintain their position on the waiting list.
- As soon as the Program Administrator has determined that there is available funding, within the affected level, adequate to reserve the first in line waiting list application, that application will be moved to active status and, if all application deficiencies have been satisfactorily fixed, the Program Administrator will issue a Conditional Reservation Notification. The incentive amount is based on the date all information is received (i.e. if the information was received after the incentive had been reduced, the application is subject to the lower incentive rate).
- If a waiting list exists at the end of a program year, the Program Administrator will notify the Host Customer of any incentive or eligibility rule changes. If the Host Customer wishes to withdraw their application from the waiting list, they must promptly inform the Program Administrator.

4.4.8 Conditional Reservation Notice Letter

The Conditional Reservation Notice Letter confirms that a specific incentive amount is conditionally reserved for a self-generation Project. The letter will list, at a minimum, the approved incentive amount and the Proof of Project Advancement Milestone Date. All reservations are conditional until the Proof of Project Advancement documentation is submitted and a signed SGIP Contract on or before the Proof of Project Advancement Milestone Date. The Conditional Reservation Notice Letter also will list the required information that must be submitted by the Proof of Project Advancement Milestone Date to confirm their reservation and maintain an active status.

4.4.9 Reservation Period

Incentives can be reserved for up to 12-months for non-public entities and 18-months for Public Entities. Once a Reservation Request Form and application package is determined to be complete and eligible, the Program Administrator will (depending upon funding availability) conditionally reserve a specific dollar

amount for a specified Project system size. The initial reservation is only valid for 60 calendar days. Within 60 calendar days of the date the Conditional Reservation Letter, all Proof of Project Advancement criteria, including returning a signed SGIP Contract, must be satisfied. Once the application documentation has successfully demonstrated Proof of Project Advancement, the Program Administrator will issue a Reservation Confirmation and Incentive Claim Form with a Reservation Expiration Date of 12-months for non-public entities and 18-months for Public Entities from the date of the initial Conditional Reservation Notice Letter.

4.5 Proof of Project Advancement

Within 60 calendar days of the date on the Conditional Reservation Letter, documentation must be supplied to demonstrate to the Program Administrator that the Project is progressing and that there is a sustained commitment to complete the Project. Non-public entities, within 60 calendar days of the date the Conditional Reservation Letter, must satisfy all Proof of Project Advancement criteria, including returning a signed SGIP Contract. Public Entities, within 60 calendar days of the date the Conditional Reservation Letter, must submit a copy of the issued request for proposal (RFP or equivalent) for purchase or installation of the generating system and within 240 calendar days of the date the Conditional Reservation Letter satisfy all Proof of Project Advancement criteria, including returning a signed SGIP Contract. Once the Applicant has successfully met Proof of Project Advancement requirements, the Program Administrator will issue a Reservation Confirmation and Incentive Claim Form with a Reservation Expiration Date of 12-months from the date of the initial Conditional Reservation Notice Letter for non-public entities and 18-months from the date of the initial Conditional Reservation Notice Letter for Public Entities.

4.5.1 Required Attachments

In addition to a completed SGIP Contract, with original signatures of System Owner and Host Customer, all applications must provide a copy of the following:

Table 4-2 Proof of Project Advancement Required Materials

Required Materials	Photovoltaics & Wind Turbines	Renewable Fueled Fuel Cells, IC Engines, Gas Turbines & Microturbines	Non-Renewable Fueled Fuel Cells	Non-Renewable and Waste Gas Fueled IC Engines, Gas Turbines & Microturbines
1. Completed Proof of Project Advancement Checklist	✓	✓	✓	✓
2. Self-Generation Incentive Program Contract w/ Original Signatures.	✓	✓	✓	✓

Required Materials	Photovoltaics & Wind Turbines	Renewable Fueled Fuel Cells, IC Engines, Gas Turbines & Microturbines	Non-Renewable Fueled Fuel Cells	Non-Renewable and Waste Gas Fueled IC Engines, Gas Turbines & Microturbines
3. Proof of Insurance	✓	✓	✓	✓
4. Copy of Completed Interconnection Application	✓	✓	✓	✓
5. Copy of Executed Contract or Agreement for Installation for non-Public Entities	Non-Public Entities only ✓	Non-Public Entities only ✓	Non-Public Entities only ✓	Non-Public Entities only ✓
6. Copy of RFP or executed agreement for System Installation and/or Purchase for Public Entities	Public Entities only ✓	Public Entities only ✓	Public Entities only ✓	Public Entities only ✓
7. Project Cost Breakdown Worksheet	✓	✓	✓	✓
8. Revised Sizing Calculations (if applicable)	✓	✓	✓	✓
9. Revised Incentive Calculations (if applicable)	✓	✓	✓	✓
10. Revised Efficiency & Waste Heat Utilization Calculations (if applicable)	✓	✓	✓	✓
11. Copy of Completed Air Pollution Permit Application	N/A	✓ If Applicable	✓ If Applicable	✓ If Applicable
12. Fuel Cleanup Equipment Purchase Order	N/A	✓	N/A	N/A
13. Renewable Fuel Affidavit	N/A	✓	N/A	N/A
14. Waste Gas Fuel Affidavit	N/A	N/A	N/A	✓ Waste Gas Fuel Only

- ❖ **Proof of Project Advancement Checklist** – All Proof of Project Advancement submittals must be accompanied by a completed and signed checklist.
- ❖ **SGIP Contract** – All Proof of Project Advancement submittals must include an executed SGIP Contract with original signatures. The Host Customer and, if different from the Host Customer, the System Owner must sign the SGIP Contract.

- ❖ **Proof of Insurance** –All applications must provide proof of insurance for the Host Customer (and System Owner where applicable) in accordance with Section 18.0 and Appendix D of the SGIP Contract.
 - ❖ **Electrical Interconnection Application** – All applications must include a copy of a completed and signed application to interconnect a generating facility submitted to the local Electric Utility. For more information on the utility interconnection process, see Section 5.1. Applicants, Host Customers and System Owners are solely responsible to submit interconnection applications to the appropriate electric utility interconnection department as soon as the information to do so is available to prevent any delays in system parallel operation.
 - ❖ **Executed Contract or Agreement for System Installation or Lease for Non-Public Entities** – Non-public entities must include a copy of executed contract for purchase and installation of the system, and/or alternative System Ownership agreement. Copies of executed equipment purchase orders, construction contracts and any other agreements pertaining to this Project must be provided. Agreements must be legally binding and clearly spell out the scope of work, terms, price, generating system components to be installed. Agreements must be signed by appropriate parties (Host Customer, Installer, and/or System Owner)
 - ❖ **Request for Proposals (RFP) Documentation for Public Entities** – Public Entities must submit a copy of Request for Proposals (RFP), Notice to Invite Bids, or similar solicitation issued for the installation, lease and/or purchase for systems proposed for the SGIP. The RFP must include sufficient documentation details including the scope of work, schedule, terms, budget, generating system components to be installed. The executed contract, or agreement for system installation or lease, or a purchase order or alternate system ownership agreement must be submitted within 240 calendar days of the date the Conditional Reservation Letter satisfy all Proof of Project Advancement criteria, including returning a copy of executed contract for purchase and installation of the system, and/or alternative System Ownership agreement.
- For Public Entities not issuing an RFP, an executed contract, or agreement for system installation or lease, or a purchase order or alternate system ownership agreement must be submitted within 60 calendar days of the date the Conditional Reservation Letter. Copies of executed construction contracts and any other agreements pertaining to this Project must be provided. Agreements must be legally binding and must clearly spell out the scope of work, terms, price and generating system components to be installed. Agreements must be signed by appropriate parties (Host Customer, Installer, Applicant and/or System Owner)
- ❖ **Project Cost Breakdown** - All applications, including for turnkey and lease Projects, must include a breakdown of known and estimated Project cost elements. For a list of total eligible Project cost elements costs to be reported, see Appendix B. Applications are required to use the Project Cost Breakdown worksheet (spreadsheet), available from Program Administrator's website or by e-mail

request. The Program Administrator reserves the right to revise conditional reservation amount pending a review and approval of total eligible Project cost and incentive amounts applied for or received.

- ❖ **Revised Sizing Calculations** – When applicable, applications must include a thorough description of any changes that have occurred in the system design effecting size or incentive amount since the initial application submittal. If funding is not available, the Program Administrator cannot increase the reserved incentive amount regardless of the changes to the proposed generating system.
- ❖ **Revised Incentive Calculation Worksheet** – When applicable, all applications are required to include a revised Incentive Calculation Worksheet if system or Project changes have resulted in a change to the incentive amount. The Incentive Calculation Worksheet calculates the incentive and adjusts for other incentives and Project cost.
- ❖ **Revised Efficiency and Waste Heat Utilization Calculations** – When applicable, application documentation must include a thorough description of any changes that have occurred in the system design effecting efficiency including P.U. Code 218.5 waste heat utilization performance or minimum system efficiency. The Program Administrator will cancel any application where changes have resulted in system's inability to maintain its eligibility for waste heat utilization, minimum system efficiency or emissions standard.
- ❖ **Air Permit Application (Fuel Cells, Microturbines, Internal Combustion Engines & Gas Turbines)** – Proof of Project Advancement documentation must include copies of air pollution permitting applications, such as a Permit to Construct or Operate signed and submitted to the Local Air District. Applicants, Host Customers and System Owners are solely responsible to submit air pollution permitting applications to the Local Air District as soon as the information to do so is available to prevent any delays in system permitted operation.
- ❖ **Fuel Cleanup Equipment Purchase Order (Level 2 Fuel Cells, Microturbines, Internal Combustion Engines & Gas Turbines)** – When applicable, application documentation must include a purchase order for Renewable Fuel cleanup equipment.
- ❖ **Renewable Fuel Use Affidavit (Level 2 Fuel Cells, Microturbines, Internal Combustion Engines & Gas Turbines)** – When applicable, application documentation must include a signed SGIP affidavit that they will not switch to fossil fuel for a period of five years for fuel cells or three years for all other technologies, or the life of the equipment, whichever is shorter.
- ❖ **Waste Gas Fuel Use Affidavit (Waste Gas Only)** – When applicable, application documentation must include a signed SGIP affidavit that they will fuel their Project solely (100%) with Waste Gas for a period of five years for fuel cells or three years for all other technologies, or the life of the equipment, whichever is shorter.

4.5.2 Changes to the Proposed System

The Program Administrator will expect a system to be installed as described in the Reservation Request Form, but recognizes that minor changes may result during installation and that substantive changes may be necessary in extraordinary circumstances.

4.5.2.1 Substantive Changes to the Proposed Project

Substantive changes, including changes to those items included in the System Description Worksheet, such as change of System Owner, incentive payment recipient, Project location, or changes in equipment type, require prior approval by the Program Administrator for the reservation to remain in force. Requests for substantive Project changes must be requested in writing.

4.5.2.2 System Changes Affecting Incentive Amount

If all available funds are reserved for other Projects, the Program Administrator cannot raise the originally reserved incentive amount.

If any change results in the installed system differing in its rated electrical output from the system originally specified in the Reservation Request Form, a new incentive payment amount will be calculated. If the proposed system is smaller in output and its eligible costs are lower than those specified in the Reservation Request Form, the applications will receive the smaller incentive amount.

If the proposed system is larger or more expensive than that originally specified in the Reservation Request Form, the Program Administrator may accept the revised incentive as reported in the submitted Proof of Project Advancement documentation. There is no guarantee, however, that Projects who increase the size of the system from that originally stated in the Reservation Request Form will receive the higher incentive amount.

If system size is increased after a conditional reservation has been issued, an incentive amount is calculated at the current SGIP incentive rate for the entire system size. This new incentive amount is compared to the Conditional Reservation amount and the larger of the two becomes the incentive amount.

4.5.3 Submitting Proof of Project Advancement

Once the Proof of Project Advancement package is complete and all the required attachments are secured, the application package must be submitted to the Program Administrator for review. Faxed or hand delivered applications are not allowed. To ensure confirmation of receipt, documentation is to be delivered to the appropriate Program Administrator by certified or overnight mail. No faxes or hand deliveries will be accepted.

4.5.4 Incomplete Proof of Project Advancement

If a complete Proof of Project Advancement package is not received by the Proof of Project Advancement Milestone Date, the application will be cancelled by the Program Administrator.

If submitted Proof of Project Advancement documentation is complete but requires clarification, the Program Administrator will request the information necessary to process that application further. Applicants have 20 calendar days to respond with the necessary information. If, after 20 calendar days, the requested information has not been submitted, the application will be canceled.

4.5.5 Proof of Project Advancement Extensions

In general, no extensions to the Proof of Project Advancement Milestone Date are permitted.

An extension of the Proof of Project Advancement Date may be granted only for Host Customers that are Public Entities up to a maximum of 60 days at the Program Administrator's discretion. Any extension granted does not automatically extend the Reservation Expiration Date. Applicants and Host Customers must demonstrate that failure to submit a complete Proof of Project Advancement package was for reasons beyond their control (e.g., board agenda describing approval of Project and award of bid at next meeting). If the Proof of Project Advancement Date expires and no extension is granted, the application is considered terminated. Applicants and Host Customers may reapply for an incentive, but such re-applications will be processed in sequence along with other new applications.

4.5.6 Submitting the Executed Contract or Agreement for System Installation or Lease for Public Entities

Public Entities that submitted a copy of an RFP at the Proof of Project Advancement deadline, within 60 days of the date on the Conditional Reservation Letter, must submit a copy of an executed contract for purchase and installation of a system, and/or alternate System Ownership agreement 240 days of the date on the Conditional Reservation Letter. Copies of executed equipment purchase orders, construction contracts and any other agreements pertaining to this Project must be provided. Agreements must be legally binding and clearly detail the scope of work, terms, budget, schedule and generating system components to be installed. Agreements must be signed by appropriate parties (Host Customer, Installer, Applicant and/or System Owner). If the executed contract for purchase and installation of the system and/or alternative System Ownership agreement is not submitted within the 240 days from the date of the Conditional Reservation Letter, the application will be cancelled and the application fee will be forfeited.

4.5.7 Approval of Proof of Project Advancement

Once applications have successfully demonstrated Project advancement the Program Administrator will return executed copy(ies) of the SGIP Contract and issue a Reservation Confirmation and Incentive Claim Form. This form will list the specific reservation dollar amount and the Reservation Expiration Date. Upon Project completion and prior to the Reservation Expiration Date, completed Reservation Confirmation and Incentive Claim Form must be submitted along with all of the necessary documentation to request an incentive payment.

4.6 Reservation Confirmation and Incentive Claim Form

After an eligible generating system is completed, Applicants may request payment of the incentive amount listed on their Reservation Confirmation and Incentive Claim Form. A generating system is considered “completed” when it is completely installed, interconnected, permitted, paid for and capable of producing electricity in the manner and in the amounts for which it was designed. Payment will be disbursed once the Program Administrator verifies that the generating system is “completed” and meets all the eligibility requirements of the SGIP.

4.6.1 Extending the Reservation Expiration Date

A request to extend the Reservation Expiration Date of the reservation is limited to a maximum of 180 calendar days of additional time. Any request must include a written explanation of why the extension is required and how much additional time is needed. Approval of a request for a change in Reservation Expiration Date will not change or modify any other reservation condition. Failure to submit the Incentive Claim package by the original or extended Reservation Expiration Date will result in a cancellation of the application.

4.6.2 Requesting an Incentive Payment

To request an incentive payment, the Reservation Confirmation and Incentive Claim Form must be completed and submitted. Both System Owner and Host Customer must sign the Reservation Confirmation and Claim Form.

Please note that no incentive payment will be made until the Program Administrator has verified by field inspection that the system is operational and interconnected. See Section 4.6.7.

The completed Reservation Confirmation and Incentive Claim Form must be submitted to the Program Administrator on or before the Reservation Expiration Date, together with all required attachments described below.

4.6.3 Required Attachments

In addition to the completed Reservation Confirmation and Incentive Claim Form, the following attachments must be submitted when requesting incentive payment:

Table 4-3 Reservation Confirmation and Incentive Claim Required Materials

Required Materials	Photovoltaics & Wind Turbines	Renewable Fueled Fuel Cells, IC Engines, Gas Turbines & Microturbines	Non-Renewable Fueled Fuel Cells	Non-Renewable and Waste Gas Fueled IC Engines, Gas Turbines & Microturbines
1. Completed Incentive Claim Form Checklist	✓	✓	✓	✓

Required Materials	Photovoltaics & Wind Turbines	Renewable Fueled Fuel Cells, IC Engines, Gas Turbines & Microturbines	Non-Renewable Fueled Fuel Cells	Non-Renewable and Waste Gas Fueled IC Engines, Gas Turbines & Microturbines
2. Completed Incentive Claim Form w/ Original Signatures	✓	✓	✓	✓
3. Proof of Authorization to Interconnect	✓	✓	✓	✓
4. Final Building Inspection Report	✓	✓	✓	✓
5. Proof of Warranty	✓ Five Years	✓ Three Years Five Years for Fuel Cells	✓ Five Years	✓ Three Years
6. Final Project Cost Breakdown and Affidavit	✓	✓	✓	✓
7. Final Incentive Calculation Worksheet	✓	✓	✓	✓
8. Substantiation of Load	✓ New Construction Only	✓ New Construction Only	✓ New Construction Only	✓ New Construction Only
9. Substantiation of Renewable Fuel Resource	N/A	✓	N/A	N/A
10. Revised Sizing Calculations (if applicable)	✓	✓	✓	✓
11. Revised Efficiency & Waste Heat Recovery Calculations (if applicable)	✓	✓	✓	✓
12. Final Fuel Cleanup Skid Cost Documentation	N/A	✓	N/A	N/A
13. Final Air Permit Documentation	N/A	✓ If Applicable	✓ If Applicable	✓ If Applicable
14. Planned Maintenance Coordination Letter	N/A	N/A	N/A	✓ If >200 kW
15. AQMD or APCD Determination of Onsite Net Emissions Benefit	N/A	N/A	N/A	✓ Waste Gas Fuel Only

- ❖ **Reservation Confirmation and Incentive Claim Checklist** – All Reservation Confirmation and Incentive Claim submittals must be accompanied by a completed and signed checklist.
- ❖ **Reservation Confirmation and Incentive Claim Form** – A completed Reservation Confirmation and Incentive Claim form must be submitted with all applications. It must be completed and signed by representatives with signature authority for both the System Owner and Host Customer. The installer's name, telephone number and contractor license number must be included with the completed Reservation Confirmation and Incentive Claim Form. Only applications with original signatures on a single form will be accepted. Any changes in the system upon completion of the Project that affect the system capacity, waste heat utilization, minimum system efficiency or Project cost must include supporting documentation and a recalculated incentive. If a waiting list exists, no increases in incentive will be allowed.
- ❖ **Proof of Authorization to Interconnect** – A copy of the signed letter from their Electric Utility granting the Host Customer and/or System Owner permission to interconnect and operate in parallel with the local grid. For questions on the interconnection process, see Section 5.1.
- ❖ **Final Building Inspection Report** – A copy of the final building inspection report demonstrating that the Project meets all codes and standards of the permitting jurisdiction. Contact your local permitting jurisdiction to learn about permitting requirements.
- ❖ **Proof of Warranty** – Proof of a warranty, extended warranty and/or maintenance agreement in accordance with Section 2.5.12 of this Handbook.
- ❖ **Final Project Cost Breakdown and Affidavit** – A final Project cost breakdown worksheet, along with a signed affidavit substantiating the claimed eligible Project cost. The Program Administrator reserves the right to withhold final incentive payment pending review and approval of Project cost and receipt of supporting documentation. For a list of total eligible Project cost, see Appendix C. The Program Administrator reserves the right to periodically audit Host Customer's and, if different from Host Customer, the System Owner's records. See Section 21.0 of the SGIP Contract.
- ❖ **Final Incentive Calculation Worksheet** – All applications are required to include a completed Incentive Calculation Worksheet, available from Program Administrator's website, using the Project's final and actual system size, Project cost and other incentives.
- ❖ **Substantiation of Load (New or Added Load Projects Only)** – For Projects where Host Customer estimated future load was used to justify system size, applications must include documentation demonstrating that the load forecast has materialized.
- ❖ **Substantiation of Renewable Fuel Resource (Level 2 Projects except wind turbines)** – For Projects where Host Customer provided Renewable Fuel resource estimates, applications must include documentation demonstrating that the Renewable Fuel resource has materialized.

- ❖ **Revised Sizing Calculations** – When applicable, applications must include a thorough description of any changes that have occurred in the system design effecting size or incentive amount since the initial application submittal. If funding is not available, the reserved incentive cannot be increased amount regardless of the changes to the proposed generating system.
- ❖ **Revised Efficiency and Waste Heat Utilization Calculations** – When applicable, the application must include a thorough description of any changes that have occurred in the system design effecting efficiency including P.U. Code 218.5 waste heat utilization performance or minimum system efficiency. The Program Administrator will cancel any application where changes have resulted in system's inability to maintain its eligibility for waste heat utilization, minimum system efficiency or emissions standard.
- ❖ **Fuel Cleanup Skid Cost Documentation (Level 2 Fuel Cells, Microturbines, Internal Combustion Engines & Gas Turbines)** – When applicable for Renewable Fuel Projects, applications must include documentation substantiating the fuel cleanup skid cost.
- ❖ **Final Air Permitting Documentation (Fuel Cells, Microturbines, Internal Combustion Engines & Gas Turbines)** – For those technologies that require an air permit, the application must include a copy of the final documentation indicating compliance with all applicable air pollution regulations. Typically, this is a Permit to Operate issued by the local air district.
- ❖ **Planned Maintenance Coordination Letter (Level 3 Microturbines, Internal Combustion Engines & Gas Turbines Projects Sized Over 200 kW Only)** – When applicable, applications with Level 3 microturbine, internal combustion engine and gas turbine systems sized greater than 200 kW must include a maintenance coordination letter to the Host Customer's Electric Utility. A copy of the coordination letter must also be sent to the Program Administrator, which shows the System Owner will schedule planned maintenance only between October and March and, if necessary, only during off-peak hours and/or weekends during the months of April to September (see Section 2.5.11).
- ❖ **Air Quality Management District or Air Pollution Control District Determination (Waste Gas Fuel Only)** – For Projects operating on Waste Gas fuel, applications must include a written determination from the local air quality permit authority that operation of the Project will produce an onsite net air emissions benefit.

4.6.4 Changes to the Proposed System

The Program Administrator will expect a system to be installed as described in the Reservation Confirmation and Incentive Claim Form, but recognizes that minor changes may result during installation and that substantive changes may be necessary in extraordinary circumstances.

4.6.4.1 Substantive Changes to the Proposed Project

Substantive changes, including changes to those items included in the System Description Worksheet, such as change of System Owner, incentive payment recipient, Project location, or changes in equipment

type, require prior approval by the Program Administrator for the reservation to remain in force. Requests for substantive Project changes must be requested in writing.

4.6.4.2 System Changes Affecting Incentive Amount

If all available funds are reserved for other Projects, the Program Administrator cannot raise the originally determined incentive amount.

If any change resulted in the installed system differing in its rated electrical output from the system originally specified in the Reservation Request Form, a new incentive payment amount will be calculated. If the installed system is smaller in output and its eligible costs are lower than those specified in the Reservation Request Form, the Host Customer will receive the smaller incentive amount.

If the installed system is larger or more expensive than that originally specified in the Reservation Request Form, the Program Administrator may accept the revised incentive as reported in the submitted Reservation Confirmation and Incentive Claim form. There is no guarantee, however, that Host Customers who increase the size of the system from that originally stated in the Reservation Request Form will receive the higher incentive amount.

If system size is increased after a conditional reservation has been issued, an incentive amount is calculated at the current SGIP incentive rate for the entire system size. This new incentive amount is compared to the amount originally reserved by the Host Customer and the larger of the two becomes the incentive amount.

Example #6: 245 kW Level 1 System Size Increase to 345 kW

The existing reservation is \$686,000 for a 245 kW system at a \$2.80/W incentive rate.

The Host Customer adds 100 kW for a total of 345 kW at the time of payment or when modifying the existing reservation and the current rebate level is \$2.50/W, the Project's new incentive amount is $345,000 \text{ W} \times \$2.50/\text{W} = \$862,500$. The Host Customer would receive a higher incentive than what was originally reserved *if* funding is available.

Example #7: 245 kW Level 1 System Size Increase to 280 kW

The existing reservation is \$686,000 for a 245 kW system at a \$2.80/W incentive rate. The current rebate level is \$2.50.

The Host Customer adds 25 kW for a total of 280 kW, the Project would qualify for $270,000 \text{ W} \times \$2.50/\text{W} = \$675,000$. In this case, the Host Customer would *not* qualify for additional funding due to an increase in capacity and the existing reservation for 245 kW would remain in force.

4.6.5 Submitting Your Incentive Claim Form

Once the Incentive Claim Form is complete and all the required attachments are secured, the application must be submitted to the Program Administrator. To ensure confirmation of receipt, documentation shall

be delivered to the appropriate Program Administrator by certified or overnight mail. No faxes or hand deliveries will be accepted.

4.6.6 Reservation Confirmation and Incentive Claim Submittals

If a complete Reservation Confirmation and Incentive Claim package is not received by the Reservation Expiration Date of the reservation, the application may be cancelled by the Program Administrator.

If submitted Reservation Confirmation and Incentive Claim documentation are complete but require clarification, the Program Administrator will request the information necessary to process that application.

4.6.7 Field Verification Visit

Upon receipt of a complete Incentive Claim Form package, the Program Administrator will conduct a field verification visit to verify that the Project system is installed as represented in the application, is operational, interconnected and conforms to the eligibility criteria of the SGIP. If the Project is a Level 2 (except wind turbines) or Level 3 Waste Gas technology, the availability and flow rate of the Renewable Fuel or Waste Gas will be demonstrated by Host Customer and/or System Owner. If the eligible system size depended on new construction or load growth, the required load will be confirmed at the time of Field Verification Visit. The Program Administrator also will verify system capacity rating to confirm the final incentive amount.

4.6.7.1 Failed Field Verification

If the field verification visit process determines that the system is not eligible, the Program Administrator will notify the Applicant, Host Customer and System Owner the reasons for system ineligibility. The Applicant, Host Customer and System Owner will have 30 calendar days to bring the system into compliance. A subsequent inspection visit will be conducted to determine final approval. If the Applicant, Host Customer and System Owner fails to bring the system to full eligibility within the 30 days the application will be cancelled.

If the Site load or renewable fuel forecast has not yet materialized, the Applicant will be given two options; 1) Receive a one time payment based on the Site load or fuel availability (whichever is less) demonstrated at the time of inspection or, 2) Wait for the Site load or fuel to materialize within 12-months of the date of inspection. If the Site load or fuel has not materialized within the 12-month period, the project will be paid based on the Site load, or system operating capacity available at the end of the 12-month period.

4.6.8 Incentive Check Payment and Terms

Upon final approval of the incentive claim form documentation and completed field verification visit, the Program Administrator will issue the incentive in approximately 30 days. Payment will be made to the Host Customer, System Owner, or a third party (as designated), as indicated on the Confirmation and Incentive Claim Form, and will be mailed to the address provided. The Host Customer and System

Owner, if different, may assign payment to a third party by submitting a completed payment assignment letter to the Program Administrator with the Incentive Claim. A payment assignment letter can be requested from the Program Administrator or downloaded from the Program Administrator website. The lump sum incentive payment issued constitutes final and complete payment.

5 OTHER INSTALLATION REQUIREMENTS & CONTINUING SITE ACCESS REQUIREMENTS

5.1 Connection to the Utility Distribution System

All distributed generation systems receiving incentives under the SGIP must be connected to the local Electric Utility's distribution system. The interconnection, operation, and metering requirements for generating systems shall be in accordance with the local Electric Utility rules for customer generating facility interconnections. In order to connect a generating system to the utility distribution system, Host Customers and/or System Owners will be required to execute certain documents such as, but not limited to, an "Application to Interconnect a Generating Facility" and a "Generating Facility Interconnection Agreement" with the local Electric Utility. A copy of these documents must be submitted within 60 calendar days for non-public entities and within 240 calendar days for Public Entities of the date the Conditional Reservation Notice was issued (see Section 4.5). A copy of Generating Facility Interconnection Agreements also must be submitted with the utility's written certification of interconnection and parallel operation to the Program Administrator prior to the Reservation Expiration Date.

Applicants, Host Customers and System Owners are solely responsible to submit interconnection applications to the appropriate electric utility interconnection department as soon as the information to do so is available to prevent any delays in system parallel operation.

5.1.1 How to Apply For Interconnection of Self Generation Systems

For more information on electric grid and/or natural gas pipeline interconnections, please contact your local utility (investor owned utilities are listed below). It is the sole responsibility of the SGIP System Owner and Host Customer to seek and obtain approval to interconnect the self-generation system to a utility's distribution system. System Owners and Host Customers participating in the SGIP should immediately contact the utility to seek guidance on how to apply for interconnection. Contact information is listed below.

Pacific Gas & Electric (PG&E)

Website: www.pge.com/gen

Email: gen@pge.com

Phone: (415) 972-5676 (PG&E Generation Interconnection Hotline)

San Diego Gas & Electric (SDG&E)

Website: www.sdge.com/business/self_generation.shtml

Contact information for photovoltaics and wind systems:	
Net Metering Team San Diego Gas & Electric PO Box 129831, CP52F San Diego, CA 92123-9749 Phone: (858) 636-5585 Email: netmetering@semprautilities.com	Ken Parks San Diego Gas & Electric PO Box 129831, CP52F San Diego, CA 92123-9749 Phone: (858) 636-5581 Email: kparks@semprautilities.com

All other systems:	
Self Generation Team San Diego Gas & Electric PO Box 129831, CP42K San Diego, CA 92123-9749 Phone: (858) 654-1281 Email: selfgensd@semprautilities.com	Martha Garibay San Diego Gas & Electric PO Box 129831, CP42K San Diego, CA 92123-9749 Phone: (858) 654-1281 Email: selfgensd@semprautilities.com

Southern California Edison (SCE)

Gerome Torribio
Southern California Edison
2244 Walnut Grove Avenue
Rosemead, Ca 91770
Phone: (626)302-9669
E-mail Gerome.Torribio@sce.com

Southern California Gas Company (SoCalGas)

www.socalgas.com
Residential Customers: (800) GAS-2200
Business Customer: (800) GAS-2000

5.2 Measurement and Evaluation (M&E) Activities

As a condition of receiving incentive payments under the SGIP, System Owners and Host Customers agree to participate in Measurement and Evaluation (M&E) activities as required by the CPUC. M&E activities will be performed by the Program Administrator or the Program Administrator's independent third-party consultant and include but are not limited to, periodic telephone interviews, on-site visits, development of a M&E Monitoring Plan, access for installation of metering equipment, collection and

transfer of data from installed system monitoring equipment, whether installed by Host Customer, System Owner, a third party, or the Program Administrator.

5.2.1 Field M&E Visits

During the course of the Project, the Program Administrator or the Program Administrator's independent third-party consultant will require to visit the Site for M&E purposes. These field M&E visits can occur before, during or after startup of the generating system for the purposes of developing a monitoring plan, installing additional M&E instrumentation, perform equipment operations inspection and retrieving system data. These visits are separate and distinct from the field verification visits (see Section 4.6.7) by the Program Administrator or their consultants, which are used to determine eligibility of the installed generating system and occur during the Incentive Claim stage of the application process.

5.2.2 Electrical Metering Requirements

At the discretion of the Program Administrator, and in consultation with the M&E contractor, SGIP systems may require installation of dedicated, recording, time-of-use or interval metering to measure and record electrical generation output (i.e. Net Generation Output Meter) solely for M&E purposes. Many installations will already require this type of electrical metering as a condition of interconnection with the utility grid. In the case of investor owned electric utilities, this means compliance with their filed CPUC Rule 21, Generating Facility Interconnections. Specifications for the net generation output meter can be found on the Program Administrator's or the Electric Utility's website.

Costs for metering normally required by the utility in accordance with its tariff rules shall be paid by the utility customer. Metering not normally required by the utility's rules, but required, as a condition of receiving incentives under the SGIP, shall be paid for by the Program Administrator.

5.2.3 Other Energy Metering Requirements

The CPUC requires that Level 2 (except wind turbines) and Level 3 technology installations be evaluated for compliance with SGIP requirements for efficiency, waste heat recovery, or use of renewable/non-renewable fuels. As a condition of receiving incentive payments in the SGIP, Host Customer and System Owner agree to allow the Program Administrator, or the Program Administrator's independent third-party consultant, to conduct measurement and evaluation activities on completed installations. Furthermore, the Host Customer and System Owner agree to cooperate with the installation of any additional system monitoring equipment that the M&E consultant may deem necessary. All labor and material costs for instrumentation and data collection required solely for SGIP M&E purposes (and not by utility tariff) will be paid by the Program Administrator. Results of measurement and evaluation activities will have no bearing on the incentive payment previously received, with the exception of Projects utilizing Renewable Fuels.

5.2.4 M&E System Monitoring Data Transfer Requirements

For systems with Host Customer, System Owner, third party, or Program Administrator installed monitoring equipment; the Host Customer and System Owner agree to provide system monitoring data (typically 15-minute interval data) to the SGIP M&E consultant on a quarterly basis.

5.2.5 Disposition of SGIP Metering Equipment

Upon completion of the SGIP M&E metering activities at the Site, the Program Administrator will offer all M&E metering equipment to the System Owner for transference. The Program Administrator will provide an Equipment Transfer Agreement with a schedule of the SGIP M&E equipment located at the Site. The Equipment Transfer Agreement must be signed by both the System Owner and the Program Administrator.

If the System Owner does not wish to accept the M&E metering equipment, the Program Administrator or its M&E contractor will remove the M&E metering equipment. The Program Administrator shall pay the costs for meter removal.

6 DEFINITIONS AND GLOSSARY

AB 970:

Assembly Bill 970, signed by Governor Davis on September 6, 2000. This legislation required the CPUC to initiate certain load control and distributed generation activities, which resulted in the SGIP.

AB 1407:

Assembly Bill 1407, codified as California Civil Code section 714, was signed by Governor Davis on September 3, 2003. Among other things, this legislation voids and makes unenforceable any existing covenant, restriction, or condition contained in any deed, contract, security instrument, or other instrument affecting real property, as specified, that prohibits or restricts the installation or use of a solar energy system, excepting provisions that impose reasonable restrictions on solar energy systems. This statute also mandates that whenever approval is required for the installation or use of a solar energy system, that such approval be processed in the same manner as approval of an architectural modification, and not be willfully avoided or delayed. Any Public Entity (see definition) may not receive funds from a state-sponsored grant or loan program, including the SGIP, for solar energy if it fails to comply with these requirements. A Public Entity must certify that it is meeting these requirements when applying for these grants or loans. Please see California Civil Code section 714 for full statutory requirements and further detail.

AB 1685:

Assembly Bill 1685, signed by Governor Davis on October 12, 2003. This legislation requires the CPUC, in consultation with the Energy Commission, to administer, until January 1, 2008, a self-generation incentive program for distributed generation resources in the same form that exists on January 1, 2004, but requires that combustion-operated distributed generation Projects using fossil fuels commencing January 1, 2005, meet a NOx emission standard, and commencing January 1, 2007, meet a more stringent NOx emission standard and a minimum system efficiency standard, to be eligible for incentive rebates under the SGIP. The bill establishes a credit for combined heat and power units that meet minimum system efficiency standard. The bill also revises the definition of an ultra-clean and low-emission distributed generation to include electric generation technologies that commence operation prior to December 31, 2008.

Applicant:

The entity, either the Host Customer, System Owner, or third party designated by the Host Customer, responsible for the development and submission of the SGIP application materials and the main point of communication between the SGIP Program Administrator for a specific SGIP Application.

Application Fee:

An Application Fee is required once the Reservation Request has been submitted. The Application Fee is 0.5% of unadjusted requested SGIP incentive and is refundable, in general, only when the Project is

completed and the incentive is paid, anytime before the application receives a Conditional Reservation, or withdrawn due to extenuating circumstances beyond the Host Customer's control.

Backup Generators:

Operate as short-term temporary replacement for electrical power during periods of utility power outages. In addition to emergency operation they ordinarily only operate for testing and maintenance. Backup generators do not produce power to be sold or otherwise supplied to the grid or provide power to loads that are simultaneously serviced by a utility electric grid. Backup generators only service customer loads that are isolated from the grid either by design or by manual or automatic transfer switch.

Calendar Days:

All dates and schedules in the SGIP are measured in calendar days, which include all days of the week.

CEC:

California Energy Commission

Corporate Parent:

For private sector entities, the holding company of the utility customer of record who is listed as the Host Customer on the Project application. In addition, other business relations such as franchises or building associations will be handled as Corporate Parents and will be held to the same limitations and caps as Corporate Parents.

CPUC:

California Public Utilities Commission

Diesel Cycle:

A diesel cycle engine uses compression ignition rather than spark igniting to ignite the fuel air mixture in the continuous production of power. Compression ignition occurs when the air, within the engine cylinder, is compressed by the piston to a high pressure and temperature. Fuel is then injected into the cylinder where it is ignited by the elevated air temperature. By contrast, a spark ignition engine uses an electric spark to ignite the compressed fuel air mixture, already within the cylinder.

Electric Utility:

The Host Customer's local electric transmission and distribution service provider for their Site.

ESCO:

Energy Service Company (ESCO), a business entity that designs, builds, develops, owns, operates or any combination thereof self-generation Projects for the sake of providing energy or energy services to a Host Customer.

Fuel Cell:

Power plants that produce electricity through an electrochemical reaction with a fuel source resulting in extremely low emissions and hot water or steam.

Gas Service:

The gas line from the Utility's distribution main to the serving gas meter

Government Parent:

A Government parent is divided into federal, state, and local government parents. Federal government parents include the Air Force, Army, Navy, Marines, Postal Service, General Services Administration, and all other Federal agencies or departments. State government parents include the University of California, California State University, Department of Corrections, Department of General Services, the combination of the Department of Developmental Services and CalTrans, the combination of the California Youth Authority and the Department of Mental Health, and all other state agencies and departments. Local government parents include cities, counties, school districts, and water districts.

Host Customer:

An entity that meets all of the following criteria: 1) has legal rights to occupy the Site, 2) receives retail level electric or gas distribution service from PG&E, SCE, SoCalGas or SDG&E, 3) is the utility customer of record at the Site 4) is connected to the electric grid, and 5) is the recipient of the net electricity generated from the self-generation equipment.

Hybrid System:

A self-generation system that combines more than one type of distributed generation technology and is located behind a single Electric Utility service meter.

Investor Owned Utility:

For purposes of the SGIP, this refers to Pacific Gas & Electric Company, San Diego Gas & Electric Company, Southern California Edison Company and Southern California Gas Company.

Inverter:

An electric conversion device that converts direct current (DC) electricity into alternating current (AC) electricity.

Inverter Efficiency:

The AC power output of the inverter divided by the DC power input.

ISO:

International Standards Organization

Maximum Site Electric Load:

The peak (maximum) kW demand at the Site, regardless if served by the existing generator, the local utility or a combination of the two.

Microturbines:

Small-scale combustion turbines ranging from 30 kW to 100 kW in size. Larger sizes are expected in the near future.

Parallel Operation:

The simultaneous operation of a self-generator with power delivered or received by the electrical utility while interconnected to the grid. Parallel Operation includes only those generators that are interconnected with the Electric Utility distribution system for more than 60 cycles.

PG&E:

Pacific Gas and Electric Company

Power Purchase Agreements:

An agreement for the sale of electricity from one party to another, where the electricity is generated and consumed on the Host Customer Site. Agreements that entail the export and sale of electricity from the Host Customer Site do not constitute on-site use of the generated electricity and therefore are ineligible for the SGIP.

Power Rating:

The rated electric generating capacity of the power plant expressed in watts, kilowatts or megawatts.

Primary Heat Recovery Equipment:

The first heat exchanger, in the waste heat recovery system, located off the generating system skid used to transfer recovered waste heat energy to a working fluid that is delivered to Thermal Application Equipment and/or directly to Thermal Load(s).

Program Year:

January 1 through December 31.

Proof of Project Advancement Milestone Date:

The Proof of Project Advancement Milestone Date is the date when required information to demonstrate that their Project is moving forward is due.

Project:

For purposes of the SGIP, the "Project" is the installation and operation of the proposed eligible self-generation technology(ies), as described by the submitted Reservation Request documentation.

Project Completion Date:

For purposes of the SGIP, the Project completion date will be determined when the Host Customer receives permission, from the Electric Utility, to operate in parallel.

PTC:

The PVUSA Test Conditions that specify the conditions for rating the power of photovoltaic systems at 1,000 W/m² irradiance, 20°C ambient temperature and 1 m/sec wind speed.

Public Entity:

Includes the state, the Regents of the University of California, a county, city, city and county, district, public authority, public agency, and any other political subdivision or public corporation in the state or any

entity acting on behalf of these agencies when acquiring real property, or any interest therein, in any city or county for public use, and any person who has the authority to acquire property by eminent domain under state law.²⁵

PV:

Photovoltaic, a technology that uses a semiconductor to convert light directly into electricity.

Renewable Fuel:

A Renewable Fuel is a non-fossil fuel resource other than those defined as conventional in Section 2805 of the Public Utilities Code that can be categorized as one of the following: solar, wind, gas derived from biomass, digester gas, or landfill gas. A facility utilizing a Renewable Fuel may not use more than 25 percent fossil fuel annually, as determined on a total energy input basis for the calendar year.

Reservation Expiration Date:

The Reservation Expiration Date is one year after the date of the Conditional Reservation Notice.

SCE:

Southern California Edison

SDG&E:

San Diego Gas and Electric

SDREO:

San Diego Regional Energy Office

Self-Generation Facility:

For the purposes of complying with the reliability criteria, a Self-Generating Facility is an on-site power generator that does not exceed the load at that facility which includes the prime mover (turbine or engine), generator, primary heat recovery equipment, and auxiliary equipment.

Site:

A single business enterprise or home located on an integral parcel or parcels of land undivided by a public road or thoroughfare regardless of the number of meters serving that Site; or if divided by a public road or thoroughfare, served by a single electric utility meter. Separate business enterprises or homes on a single parcel of land undivided by a highway, public road, thoroughfare or railroad would be considered for purposes of the SGIP as separate Sites.

SoCalGas:

Southern California Gas Company

System Owner:

The owner of the generating system at the time the incentive is paid. For example, in the case when a

²⁵ Source: CALIFORNIA CODES - GOVERNMENT CODE SECTION 7260-7277

vendor sells a turnkey system to a Host Customer, the Host Customer is the System Owner. In the case of a leased system, the lessor is the System Owner.

Thermal Application Equipment:

Thermal end-use equipment such as but not limited to absorption chillers (indirect or direct fired), boilers, water heaters, space heaters, furnaces, dryers, secondary heat exchangers, thermal storage tanks or vessels including pumps, cooling towers, and piping or any other ancillary equipment.

Thermal Load:

Host Customer heating process(es) including but not limited to industrial process heating, space heating, domestic hot water heating and/or heat input to an absorption chiller used for space cooling or refrigeration.

Waste Gas:

Natural gas that is generated as a byproduct of petroleum production operations and is not eligible for delivery to the utility pipeline system.

7 PROGRAM ADMINISTRATOR CONTACT INFORMATION

Potential Host Customers and their s can receive more information and apply for incentive funding through the following Program Administrators²⁶:

Pacific Gas & Electric (PG&E)

Website: www.pge.com/selfgen
Email Address: selfgen@pge.com
Telephone: (415) 973-6436
Fax: (415) 973-2510
Mailing Address: Self-Generation Incentive Program
P.O. Box 770000
Mail Code B29R
San Francisco, CA 94177-001

San Diego Regional Energy Office (SDREO)

Website: selfgen.sdenergy.org
Contact Person: Nathalie Osborn, Program Manager
Telephone: (858) 244-1193
Fax: (858) 244-1178
Email: selfgen@sdenergy.org
Address: San Diego Regional Energy Office
Attn: SELFGEN Program Manager
8520 Tech Way Suite 110
San Diego, CA 92123

Southern California Edison (SCE)

Website: www.sce.com/sqip
E-mail: greenh@sce.com
Address: Program Manager Self-Generation Incentive Program
Southern California Edison
2131 Walnut Grove Avenue, 3rd Floor, B 10
Rosemead, California 91770
Telephone: 1-800-736-4777
Fax: (626) 302-6253

Southern California Gas Company (SoCalGas)

Website: www.socalgas.com/business/selfgen
E-Mail: selfgeneration@socalgas.com
Telephone: 1-866-DG-REBATE (1-866-347-3228)
Fax: (213) 244-8222
Address: Self-Generation Incentive Program Administrator
Southern California Gas Company
555 West Fifth Street, GT22H4
Los Angeles, CA 90013-1011

²⁶ Potential eligible projects located in the service territory of both Southern California Edison and the Southern California Gas Company can apply for incentive funding to either Program Administrator.

APPENDIX A

ELIGIBLE PROJECT COST ITEMS FOR LEVEL 1 PV SYSTEMS

Energy Generating Equipment	PV Mounting Systems	Electrical Balance of Systems	Labor
<ul style="list-style-type: none"> • PV modules • PV material 	<ul style="list-style-type: none"> • Fasteners – mechanical hardware, adhesive • Foundation • Free standing support structures/racks/poles • Ballast • Sealant • Tracker assembly • Mounting surface- single-ply membrane, metal roof panels • Module framing²⁷, mullion²⁸ 	<ul style="list-style-type: none"> • Inverters • Wiring/conduit • Disconnects/junction boxes 	<ul style="list-style-type: none"> • Labor directly associated with the photovoltaic installation.

²⁷ Module framing does not include building structural support members such as but not limited to roof frames, joists, beams, and columns.

²⁸ Mullion is defined by Merriam Webster as “a slender vertical member that forms a division between units of a window, door, or screen or is used decoratively.”

APPENDIX B

DESCRIPTION OF TOTAL ELIGIBLE PROJECT COSTS

The following costs may be included in total eligible Project cost:

1. Self-generation equipment capital cost
2. Engineering and design costs
3. Construction and installation costs. For Projects in which the generation equipment is part of a larger Project, only the construction and installation costs directly associated with the installation of the energy generating equipment are eligible.
4. Engineering feasibility study costs
5. Interconnection costs, including:
 - a. Electric grid interconnection application fees
 - b. Metering costs associated with interconnection
6. Environmental and building permitting costs
7. Warranty and/or maintenance contract costs associated with eligible Project cost equipment (See 2.6.2 for full explanation of eligible costs)
8. Gas line installation costs, limited to the following:
 - a. Costs associated with installing a natural gas line on the customer's Site that connects the serving gas meter or customer's natural gas infrastructure to the distributed generation unit(s).²⁹
 - b. Customer's cost for an additional (second) gas service to serve the distributed generation unit if this represents a lower cost than tying to the existing meter or gas service.
 - c. Customer's cost for any evaluation, planning, design, and engineering costs related to enhancing/replacing the existing gas service specifically required to serve the distributed generation unit.
9. Sales tax and use tax
10. On-site system measurement, monitoring and data acquisition equipment.

²⁹ In many cases, the Utility requires a separate, Utility owned gas meter, dedicated to the generator to qualify for a generation gas rate schedule. In that case, costs associated with installing a separate gas meter that are in excess of those covered under the applicable gas rules may be included as an Eligible Project Cost.

11. Air emission control equipment capital cost
12. Primary heat recovery equipment, i.e. heat recovery equipment directly connected to the generation system whose sole purpose is to collect the waste heat produced by the power plant. For example, a heat exchanger or heat recovery boiler (a.k.a., heat recovery steam generator, or HRSG) used to capture heat from a gas turbine is an eligible cost
13. Heat recovery piping and controls necessary to interconnect the generating equipment to either the Primary Heat Recovery Equipment or the heat recovery piping and controls within the space primarily occupied by the generator partitioned by a fence or wall, whichever cost is less. If there is no identifiable Primary Heat Recovery Equipment and no identifiable space primarily occupied by the generator, eligible heat recovery piping and control costs shall be limited to the generator skid.
14. Level 2 Projects (except wind turbines) may claim the cost associated with securing a bond to certify use of Renewable Fuel, described in the SGIP Contract, as eligible costs.
15. For Level 2 technologies (except wind turbines), the cost of equipment to remove moisture and other undesirable constituents from Renewable Fuels that would damage the generation equipment. Such equipment includes but is not limited to “gas skids”, dryers/moisture removal and siloxane removal towers.
16. For Level 1 PV applications only, customers may claim certain mounting surface costs as eligible Project costs. Costs may include mounting surfaces for the photovoltaic module and/or the materials that provide the primary support for the modules. Only the percentage of mounting surface directly under the photovoltaic module is eligible. See Appendix B for more information.
17. Cost of capital included in the system price by the vendor, contractor or subcontractor (the entity that sells the system) is eligible if paid by the System Owner.

APPENDIX C

CONVERSION OF EMISSIONS PPM TO LB/MWH

Procedure for Converting Emission Data to lb/MW-hr

Engines

Engine emission standards are typically expressed in terms of ppmv or in grams/brake horsepower-hour. Given below are factors to convert from ppm to grams/brake horsepower-hour and from grams/brakehorsepower-hour to pound/megawatt hour.

The resulting answers will be approximate values since various default assumptions were used to develop natural gas default factors. The efficiency of the engine has the greatest affect on the concentration (ppmvd) to mass emission rate conversion (g/bhp-hr), which can vary from 20 to 40 percent. In the calculations below, the efficiency is proportional to the engine brake specific fuel consumption.

PPM to GM/Bhp-hr

Concentration in exhaust by volume (dry) (ppmvd) = $\frac{\text{volume of pollutant (Vp)} \times 10^6}{\text{volume of exhaust (Ve)}}$

Vp = emission factor (g/bhp-hr) x horsepower x (1/molecular weight) x molar volume x conversion factors

Ve = F-factor for exhaust volume x excess air correction x engine brake specific fuel consumption x horsepower x conversion factors

These factors can be reduced to: ppmvd = (gm/Bhp-hr) * factor

Reciprocating Engines, natural gas fueled

Pollutant	Factor
NOx	57-59
VOC	163-170
CO	93-97

Values taken from California Air Pollution Control Officers Association (CAPCOA) report: Portable Equipment Rule Piston IC Engine Technical Reference Document, 1995.

Source: California Air Resources Board, Guidance for the Permitting of Electric Generation Technologies, Appendix C: Procedure for Converting Emission Data to lb/MW-hr, July 2002.

Lean-burn Engines, natural gas fueled

Pollutant	Factor
NOx	80
VOC	212
CO	123

Factors provided from Waukesha

GM/Bhp-hr to Lb/MW-hr

Gm/Bhp-hr x 3.07 = lb/MW-hr

- Includes 95% factor for generator efficiency
- Conversion factors for grams to pounds and brake horsepower to watts

Gas Turbines

lb/MW-hr = (emission rate [lb/MMBtu]) x (3.413 [MMBtu/MWh]) / (efficiency)

2.5 ppmvd = 0.0093 lb/MMBtu for NOx
2 ppmvd = 0.0027 lb/MMBtu for VOC
5 ppmvd = 0.013 lb/MMBtu for CO

efficiency for central station power plant is 50%

INDEX

AB 1407	4-8 , 6-1	curtailable.....	2-2
AB 1685	1-2 , 2-1, 2-9, 2-12, 6-1	demand-response	2-2
AB 970	1-1 , 6-1	diesel.....	2-6, 2-18, 6-2
affidavit.....	2-18, 2-19, 4-14, 4-19	Distributed Generation (DG) services.....	2-2
Agricultural	2-6	electric energy.....	1-1, 2-7, 2-8
air permit	4-20	electric output.....	2-8, 2-11
Air Permit.....	4-14, 4-18	Electric Output	4-6
Air Permitting	4-20	Electrical Corporation	2-2
annual peak demand.....	2-5, 2-6, 2-11	Electrical Load	2-3
Applicant.....	2-1, 2-2, 2-3, 2-5, 2-7, 2-8 , 2-9, 2-10, 2-15, 2-19, 4-3, 4-4, 4-5, 4-7 , 4-8 , 4-9, 4-10, 4-11, 4-13, 4-14, 4-15, 4-16, 4-19 , 4-20 , 4-22, 5-1, 5-2, 6-1	Electrical Metering	5-3
Applicants.....	2-2, 2-6, 2-12, 2-17, 3-3, 3-4, 4-1, 4-3, 4-5, 4-7 , 4-8, 4-9, 4-10, 4-11, 4-13, 4-14, 4-15, 4-16, 4-17, 4-19 , 4-20, 4-21, 5-1, 5-2, 7-1	eligible costs	3-3, 4-15, 4-21, 7-3, 7-4
application.....	1-2, 2-2, 2-5, 2-6, 2-7, 2-14, 2-16, 2-19, 4-1, 4-3, 4-5, 4-9, 4-10, 4-13, 4-14, 4-15, 4-16, 4-17, 4-20 , 4-22, 5-3, 6-1, 6-2, 7-3	Eligible Equipment Types	2-7
Application Fee	1-2, 4-3, 4-4, 4-10, 6-1	eligible Project cost.....	3-3, 3-4, 3-6, 3-8, 4-13, 4-19 , 7-3
Application Fees.....	4-3, 4-4	Emerging Renewables Program.....	1-1, 2-4, 2-17, 3-3, 3-4, 4-9
Backup Generators	6-2	emission credits	2-10, 4-8, 4-9
Back-Up Generators	2-6	EPA.....	2-10
California Energy Commission.....	See CEC, See CEC, See CEC, See CEC	export and sale of electricity	2-2, 6-4
California Public Utilities Commission.....	See CPUC	field demonstrations.....	2-17
CARB	2-10	field verification ..	2-6, 2-14, 2-18, 2-19, 4-22, 5-3
CEC.....	1-1, 1-2 , 2-4, 2-17, 3-3, 3-4, 4-9, 6-2	firm service.....	2-2
Certifications	2-4	Fuel Cell	2-15 , 3-5, 3-9, 6-2
Checklist	4-6 , 4-7 , 4-11, 4-12, 4-17, 4-19	fuel cells.....	2-14, 2-17, 3-2, 3-8, 4-14
Conditional Reservation.....	3, 1-2, 2-4, 2-6, 4-3, 4-4, 4-9, 4-10, 4-11, 4-13, 4-16, 5-1, 6-2, 6-5	Fuel Cleanup Skid	4-18 , 4-20
Conditional Reservation Notification	2-4, 4-10	fuel consumption..	2-7, 2-8, 2-10, 2-11, 2-18, 4-8
contractors.....	2-3, 2-4	future load	2, 2-5, 2-6, 4-19
CPUC.....	1-1, 1-2 , 1-3, 2-1, 2-3, 3-1, 5-2, 5-3, 6-1, 6-2	Future Load Growth.....	2-6
		future performance.....	2-19
		gas turbine.....	2-5, 2-9, 2-10, 2-14, 2-15, 3-9, 4-20, 7-4
		generating systems.....	2-6, 2-8, 2-14, 5-1
		Host Customer.....	2-1, 2-2, 2-3, 2-5, 2-6, 2-7, 2-11, 2-14, 2-16, 3-3, 3-5, 3-6, 4-2, 4-3, 4-4, 4-5, 4-7 , 4-10, 4-11, 4-12, 4-13, 4-16, 4-17, 4-19 , 4-20, 4-21, 4-22, 5-2, 5-3, 6-1, 6-2, 6-3, 6-4, 6-6

Host Customers	2-2, 2-4, 2-11, 3-5, 4-16, 4-21, 5-2, 7-1
Hybrid System2-3, 3-8, 3-9, 6-3
Hybrid Systems2-3, 2-4, 3-8, 4-5
incentive	1-1, 1-2 , 2-1, 2-2, 2-3, 2-4, 2-5, 2-6, 2-14, 2-15 , 2-16, 2-18, 2-19, 3-1, 3-3, 3-4, 3-5, 3-6, 3-8, 4-1, 4-4, 4-5, 4-7 , 4-9, 4-10, 4-14, 4-15, 4-16, 4-17, 4-19 , 4-20 , 4-21, 4-22, 5-2, 5-3, 6-1, 6-5, 7-1
incentive payment 4-23, 5-3
interconnection 2-16, 4-13, 4-19 , 5-1, 5-3, 7-3
Interconnection 2-5, 2-16, 4-12, 4-13, 5-1, 7-3
internal combustion engine	2-5, 2-9, 2-10, 2-14, 2-15, 4-20
internal combustion engines 2-3, 2-14, 3-2
interruptible 2-2
Inverter 6-3
inverter losses 2-4
investor-owned 1-1, 2-2
ISO conditions 2-4
Large gas turbines 3-2
Level 11	2-2, 2-1, 2-3, 3-1, 3-2, 3-8, 3-9, 4-3, 4-21, 7-2, 7-4
Level 22	2-3, 2-17, 2-18, 3-2, 3-6, 3-9, 4-8 , 4-14, 4-20 , 4-22, 5-3, 7-4
Level 32	2-3, 2-7, 2-9, 2-10, 2-14, 2-18, 2-19, 3-2, 3-6, 3-8, 3-9, 4-8 , 4-9, 4-20, 4-22, 5-3
Load Factor 2-6
local air district 2-10, 4-20
M&E 5-2, 5-3, 5-4
maintenance contract 2-15, 7-3
maintenance schedule 2-14
Maximum Size 2-5
Measurement and Evaluation	See M&E, See M&E
Metering 2-6, 5-1, 5-3, 5-4, 7-3
Microturbine 2-15
microturbines 2-14, 3-2
minimum system	1-2, 2-5, 2-9, 2-11, 4-8, 4-14, 4-19 , 4-20 , 6-1
minimum system efficiency	1-2, 2-9, 2-10, 4-8, 4-14, 4-20 , 6-1
Net Energy Metering2-2
Non-Renewable 2-4, 2-18, 3-2
NOx emission 1-2, 2-9, 2-10, 2-11, 4-8, 6-1
NOx emissions2-9, 2-10, 2-11, 4-8
other incentives	3-3, 3-4, 3-5, 3-6, 3-8, 4-7 , 4-14, 4-19
out of pocket expenses3-3
P.U. Code 218.5	2-7, 2-8, 2-11, 2-12, 4-14, 4-20
Pacific Gas and Electric Company	See PG&E, See PG&E
Permits2-5
PF4-8
PG&E 1-1, 2-1, 3-3, 4-7 , 5-1, 6-3, 6-4 , 7-1
photovoltaic	2-3, 2-4, 2-5, 2-14, 3-3, 3-8, 6-4, 7-2, 7-4
Physical permanence2-16
power factor2-14
Program Administrator	1-1, 2-1, 2-2, 2-6, 2-16, 2-18, 2-19, 3-1, 3-3, 3-6, 4-1, 4-3, 4-4, 4-5, 4-7 , 4-9, 4-10, 4-11, 4-13, 4-14, 4-15, 4-16, 4-17, 4-19 , 4-20 , 4-21, 4-22, 5-1, 5-2, 5-3, 5-4, 6-1, 7-1
Program Modification Guidelines1-3
Project size limit3-5
Proof of Project Advancement	3, 2-16, 4-4, 4-10, 4-11, 4-12, 4-13, 4-15, 4-16, 6-4
PTC 2-4, 6-4
Public Entity 4-6, 4-8 , 6-1, 6-4
Public Utilities Code 218.52-7
Publicly-owned2-2
PVUSA Test ConditionsSee PTC, See PTC

Renewable 2-3, 2-17, 2-18, 3-2, 3-9, 4-6, **4-8**, 4-11, 4-12, 4-14, 4-17, 6-5

Renewable Fuel 2-3, 2-5, 2-15, 2-17, 2-18, 3-2, 3-6, **4-8**, 4-14, **4-20**, 4-22, 6-5, 7-4

Replacement Generation 2-14

research and development..... 2-17

Reservation Confirmation and Incentive Claim Form 3, 2-4, 2-15, 4-5, 4-11, 4-16, 4-17, **4-19**, 4-20

Reservation Expiration Date 3, 4-4, 4-5, 4-11, 4-16, 4-17, 4-22, 5-1, 6-5

Reservation Request Application..... 4-6, **4-7**

Reservation Request Form 3, 4-3, 4-5, **4-7**, 4-9, 4-10, 4-15, 4-21

Residential 2-6, 5-2

retail..... 2-1, 2-2, 6-3

San Diego Gas & Electric..... See SDG&E

San Diego Regional Energy Office See SDREO, See SDREO, See SDREO, See SDREO

SCE 1-1, 2-1, 3-3, 4-4, **4-7**, 5-2, 6-3, 6-5, 7-1

SDG&E..... 1-1, 2-1, **4-7**, 5-1, 6-3, 6-5

SDREO..... 1-1, 6-5, 7-1

Self-Generation Incentive Program 2, 4-11, 7-1, See SGIP

SGIP 2, 1-1, **1-2**, 1-3, 2-1, 2-2, 2-3, 2-4, 2-5, 2-6, 2-14, 2-16, 2-17, 2-18, 2-19, 3-1, 3-3, 3-4, 3-5, 3-6, 3-8, 3-9, 4-1, 4-2, 4-3, 4-4, 4-5, **4-7**, **4-8**, 4-9, 4-10, 4-11, 4-12, 4-13, 4-14, 4-15, 4-17, **4-19**, 4-21, 4-22, 5-1, 5-2, 5-3, 5-4, 6-1, **6-2**, 6-3, 6-4, 6-5, 7-4

Small Commercial 2-6, **2-6**

small gas turbines 3-2

SoCalGas 1-1, 2-1, 3-3, 4-4, **4-7**, 5-2, 6-3, 6-5, 7-1

Southern California Edison See SCE, See SCE, See SCE, See SCE, See SCE, See SCE, See SCE

Southern California Gas Company See SoCalGas, See SoCalGas, See SoCalGas, See SoCalGas, See SoCalGas, See SoCalGas

Synthetic fuels..... 2-18

System capacity..... 2-4

System Description **2-7**, **4-6**, **4-7**, 4-15, 4-20

system efficiency..... 2-10, **4-8**

system monitoring..... 5-2, 5-3

System Owner 2-1, 2-2, 2-14, 2-15, 2-16, 3-3, 3-6, **4-7**, 4-12, 4-13, 4-15, 4-16, **4-19**, 4-20, 4-22, 5-3, 5-4, 6-5, 7-4

System Ownership..... 3, 4-13, 4-16

thermal load 2-7, **2-8**, 2-11, **4-8**

thermal output 2-8, **4-8**

third party 2-2, 4-3, 4-22, 5-2, 5-3

useful thermal output 2-7, 2-8, 2-11

waiting list 4-5, 4-9, 4-10, **4-19**

Warranty 2-15, 4-18, **4-19**, 7-3

Waste Gas 2-3, 2-14, 2-17, 2-18, 2-19, 3-2, 4-6, **4-7**, 4-8, 4-9, 4-11, 4-12, 4-14, 4-17, **4-18**, 4-20, 4-22, 6-6

waste heat 2-3, 2-7, 2-8, 2-9, 2-10, 2-11, 2-12, 3-6, 3-8, **4-8**, 4-14, **4-19**, **4-20**, 5-3, 6-4, 7-4

Waste heat utilization..... 2-7

Waste Heat/AB1685 spreadsheet 2-9, 2-11, 2-12

wind turbine..... 2-4, 2-5, 2-14, **2-15**, 2-17, 3-8

Wind turbines 3-2